

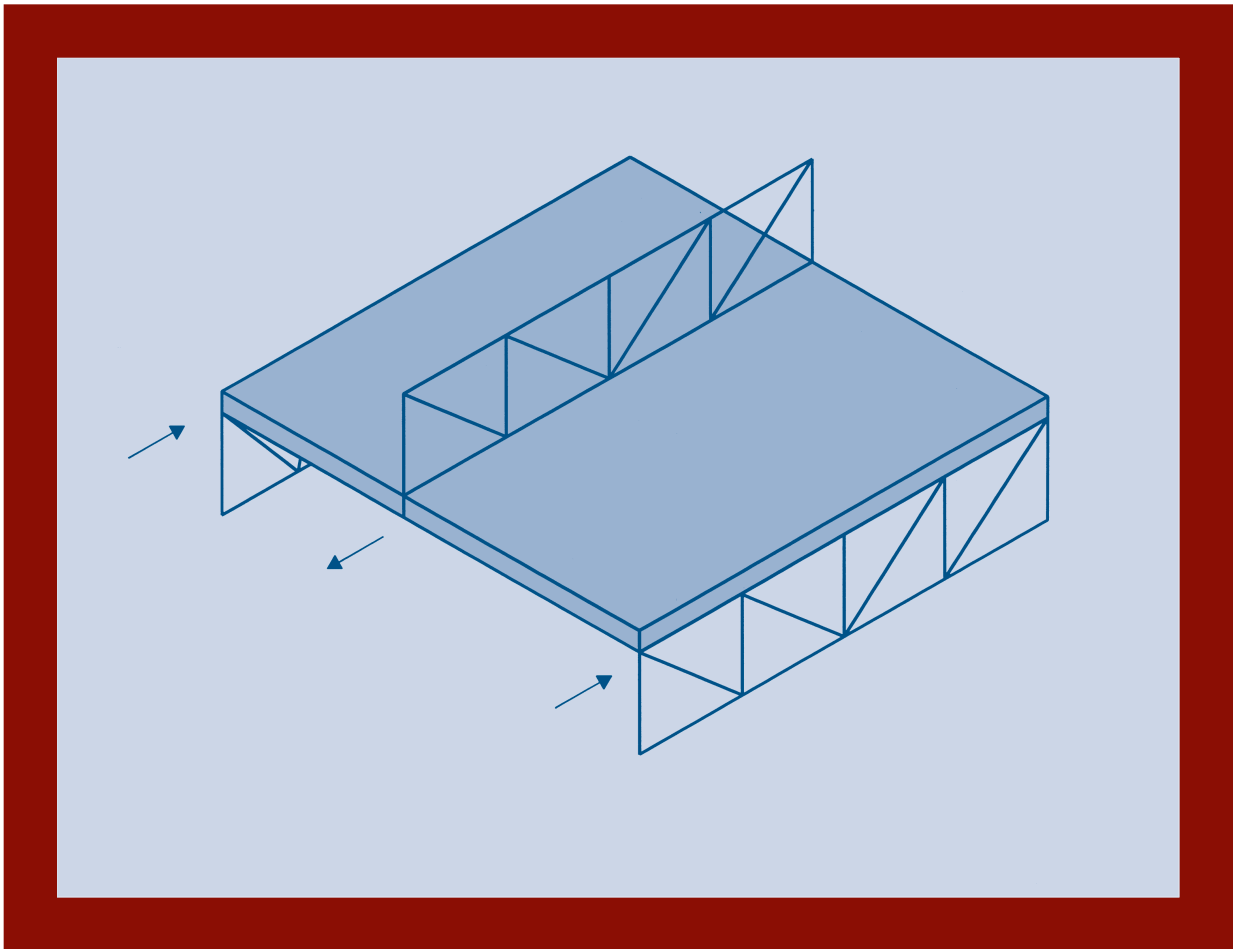

14

Steel Design Guide Series

Staggered Truss Framing Systems





14

Steel Design Guide

Staggered Truss Framing Systems

Neil Wexler, PE

Wexler Associates Consulting Engineers
New York, NY

Feng-Bao Lin, PhD, PE

Polytechnic University
Brooklyn, NY

Copyright © 2001

by

American Institute of Steel Construction, Inc.

*All rights reserved. This book or any part thereof
must not be reproduced in any form without the
written permission of the publisher.*

The information presented in this publication has been prepared in accordance with recognized engineering principles and is for general information only. While it is believed to be accurate, this information should not be used or relied upon for any specific application without competent professional examination and verification of its accuracy, suitability, and applicability by a licensed professional engineer, designer, or architect. The publication of the material contained herein is not intended as a representation or warranty on the part of the American Institute of Steel Construction or of any other person named herein, that this information is suitable for any general or particular use or of freedom from infringement of any patent or patents. Anyone making use of this information assumes all liability arising from such use.

Caution must be exercised when relying upon other specifications and codes developed by other bodies and incorporated by reference herein since such material may be modified or amended from time to time subsequent to the printing of this edition. The Institute bears no responsibility for such material other than to refer to it and incorporate it by reference at the time of the initial publication of this edition.

Printed in the United States of America

First Printing: December 2001

Second Printing: December 2002

Third Printing: October 2003

AUTHORS

Neil Wexler, PE is the president of Wexler Associates, 225 East 47th Street, New York, NY 10017-2129, Tel: 212.486.7355. He has a Bachelor's degree in Civil Engineering from McGill University (1979), a Master's degree in Engineering from City University of New York (1984); and he is a PhD candidate with Polytechnic University, New York, NY. He has designed more than 1,000 building structures.

Feng-Bao Lin, PhD, PE is a professor of Civil Engineering of Polytechnic University and a consultant with Wexler Associates. He has a Bachelor's degree in Civil Engineering from National Taiwan University (1976), Master's degree in Structural Engineering (1982), and PhD in Structural Mechanics from Northwestern University (1987).

PREFACE

In recent years staggered truss steel framing has seen a nationwide renaissance. The system, which was developed at MIT in the 1960s under the sponsorship of the U.S. Steel Corporation, has many advantages over conventional framing, and when designed in combination with precast concrete plank or similar floors, it results in a floor-to-floor height approximately equal to flat plate construction.

Between 1997 and 2000, the authors had the privilege to design six separate staggered truss building projects. While researching the topic, the authors realized that there was little or no written material available on the subject. Simultaneously, the AISC Task Force on Shallow Floor Systems recognized the benefits of staggered trusses over other systems and generously sponsored the development of this design guide. This design guide, thus, summarizes the research work and the practical experience gathered.

Generally, in staggered-truss buildings, trusses are normally one-story deep and located in the demising walls between rooms, with a Vierendeel panel at the corridors. The trusses are prefabricated in the shop and then bolted in the field to the columns. Spandrel girders are bolted to the columns and field welded to the concrete plank. The exterior walls are supported on the spandrel girders as in conventional framing.

Staggered trusses provide excellent lateral bracing. For mid-rise buildings, there is little material increase in staggered trusses for resisting lateral loads because the trusses are very efficient as part of lateral load resisting systems. Thus, staggered trusses represent an exciting and new steel application for residential facilities.

This design guide is written for structural engineers who have building design experience. It is recommended that the readers become familiar with the material content of the references listed in this design guide prior to attempting a first structural design. The design guide is written to help the designer calculate the initial member loads and to perform approximate hand calculations, which is a requisite for the selection of first member sizes and the final computer analyses and verification.

Chapter 7 on Fire Resistance was written by Esther Slubski and Jonathan Stark from the firm of Perkins Eastman Architects. Section 5.1 on Seismic Strength and Ductility Requirements was written by Robert McNamara from the firm of McNamara Salvia, Inc. Consulting Structural Engineers.

ACKNOWLEDGEMENTS

The authors would like to thank the members of the AISC Staggered Truss Design Guide Review Group for their review, commentary and assistance in the development of this design guide:

J. Steven Angell
Michael L. Baltay
Aine M. Brazil
Charles J. Carter
Thomas A. Faraone
Richard A. Henige, Jr.
Socrates A. Ioannides
Stanley D. Lindsey
Robert J. McNamara
Robert W. Pyle
Kurt D. Swensson

Their comments and suggestions have enriched this design guide. Special thanks go to Robert McNamara from McNamara Salvia, Inc. Consulting Engineers, who wrote

Section 5.1 Strength and Ductility Design Requirements. Bob's extensive experience and knowledge of structural design and analysis techniques was invaluable. Also thanks to Esther Slubski who wrote Chapter 7 on Fireproofing.

Special thanks also go to Marc Gross from the firm of Brennan Beer Gorman Architects, Oliver Wilhelm from Cybul & Cybul Architects, Jonathan Stark from Perkins Eastman Architects, Ken Hiller from Bovis, Inc., Allan Paull of Tishman Construction Corporation of New York, Larry Danza and John Kozzi of John Maltese Iron Works, Inc., who participated in a symposium held in New York on special topics for staggered-truss building structures.

Last but not least, the authors thank Charlie Carter, Steve Angell, Thomas Faraone, and Robert Pyle of the American Institute of Steel Construction Inc., who have coordinated, scheduled and facilitated the development of this design guide.

Table of Contents

Authors.....	v
Preface.....	v
Acknowledgements.....	vi

Chapter 1	
Staggered Truss Framing Systems.....	1
1.1 Advantages of Staggered Trusses.....	1
1.2 Material Description.....	1
1.3 Framing Layout.....	2
1.4 Responsibilities.....	3
1.5 Design Methodology.....	4
1.6 Design Presentation.....	4

Chapter 2	
Diaphragm Action with Hollow Core Slabs.....	7
2.1 General Information.....	7
2.2 Distribution of Lateral Forces.....	7
2.3 Transverse Shear in Diaphragm.....	9
2.4 Diaphragm Chords.....	10

Chapter 3	
Design of Truss Members.....	15
3.1 Hand and Computer Calculations.....	15
3.2 Live Load Reduction.....	15
3.3 Gravity Loads.....	15
3.4 Lateral Loads.....	17
3.5 Load Coefficients.....	17
3.6 Vertical and Diagonal Members.....	19
3.7 Truss Chords.....	19
3.8 Computer Modeling.....	19
3.9 Columns.....	21

Chapter 4	
Connections in Staggered Trusses.....	25
4.1 General Information.....	25
4.2 Connection Between Web Member and Gusset Plate.....	25
4.3 Connection Between Gusset Plate and Chord.....	27
4.4 Design Example.....	27
4.5 Miscellaneous Considerations.....	27

Chapter 5	
Seismic Design.....	29
5.1 Strength and Ductility Design Requirements.....	29
5.2 New Seismic Design Considerations for Precast Concrete Diaphragms.....	29
5.3 Ductility of Truss Members.....	29
5.4 Seismic Design of Gusset Plates.....	30
5.5 New Developments in Gusset Plate to HSS Connections.....	31

Chapter 6	
Special Topics.....	33
6.1 Openings.....	33
6.2 Mechanical Design Considerations.....	33
6.3 Plank Leveling.....	33
6.4 Erection Considerations.....	33
6.5 Coordination of Subcontractors.....	34
6.6 Foundation Overturning and Sliding.....	34
6.7 Special Conditions of Symmetry.....	35
6.8 Balconies.....	35
6.9 Spandrel Beams.....	35

Chapter 7	
Fire Protection of Staggered Trusses.....	37

References.....	39
------------------------	-----------

Chapter 1

INTRODUCTION

1.1 Advantages of Staggered Truss Framing Systems

The staggered-truss framing system, originally developed at MIT in the 1960s, has been used as the major structural system for certain buildings for some time. This system is efficient for mid-rise apartments, hotels, motels, dormitories, hospitals, and other structures for which a low floor-to-floor height is desirable. The arrangement of story-high trusses in a vertically staggered pattern at alternate column lines can be used to provide large column-free areas for room layouts as illustrated in Fig. 1.1. The staggered-truss framing system is one of the only framing systems that can be used to allow column-free areas on the order of 60 ft by 70 ft. Furthermore, this system is normally economical, simple to fabricate and erect, and as a result, often cheaper than other framing systems.

One added benefit of the staggered-truss framing system is that it is highly efficient for resistance to the lateral loading caused by wind and earthquake. The stiffness of the system provides the desired drift control for wind and earthquake loadings. Moreover, the system can provide a significant amount of energy absorption capacity and ductile deformation capability for high-seismic applications. When conditions are proper, it can yield great economy and maximum architectural and planning flexibility.

It also commonly offers the most cost-efficient possibilities, given the project's scheduling considerations. The staggered-truss framing system is one of the quickest available methods to use during winter construction. Erection and enclosure of the buildings are not affected by prolonged sub-freezing weather. Steel framing, including spandrel beams and precast floors, are projected to be erected at the

rate of one floor every five days. Once two floors are erected, window installation can start and stay right behind the steel and floor erection. No time is lost in waiting for other trades such as bricklayers to start work. Except for foundations and grouting, all "wet" trades are normally eliminated.

Savings also occur at the foundations. The vertical loads concentrated at a few columns normally exceed the uplift forces generated by the lateral loads and, as a result, uplift anchors are often not required. The reduced number of columns also results in less foundation formwork, less concrete, and reduced construction time. When used, precast plank is lighter than cast-in-place concrete, the building is lighter, the seismic forces are smaller, and the foundations are reduced.

The fire resistance of the system is also good for two reasons. First, the steel is localized to the trusses, which only occur at every 58 to 70 ft on a floor, so the fireproofing operation can be completed efficiently. Furthermore, the trusses are typically placed within demising walls and it is possible that the necessary fire rating can be achieved through proper construction of the wall. Also, the elements of the trusses are by design compact sections and thus will require a minimum of spray-on fireproofing thickness.

1.2 Material Description

A staggered-truss frame is designed with steel framing members and concrete floors. Most often, the floor system is precast concrete hollow-core plank. Other options, including concrete supported on metal deck with steel beams or joists, can be used.

With precast plank floors, economy is achieved by "stretching" the plank to the greatest possible span. 8-in.-thick plank generally can be used to span up to 30 ft, while 10-in.-thick plank generally can be used to span up to 36 ft. Specific span capabilities should be verified with the specific plank manufacturer. Therefore, the spacing of the trusses has a close relationship to the thickness of plank and its ability to span. 6-in.-thick precast plank is normally only used with concrete topping.

Hollow core plank is manufactured by the process of extrusion or slip forming. In both cases the plank is prestressed and cambered. The number of tendons and their diameter is selected for strength requirements by the plank manufacturer's engineer based upon the design instructions provided by the engineer of record.

The trusses are manufactured from various steels. Early buildings were designed with chords made of wide-flange sections and diagonal and vertical members made of chan-

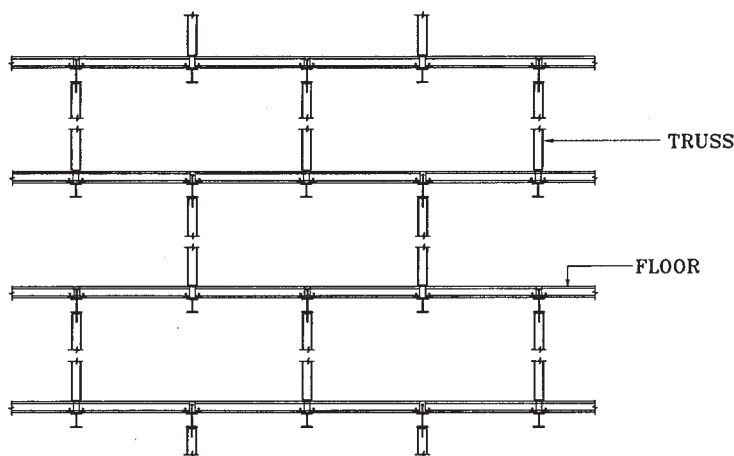

Fig. 1.1 Staggered-truss system-vertical stacking arrangement.

Table 1.1 Material Guide			
	Section	ASTM	Fy (ksi)
Columns and Truss Chords	Wide Flange	A992 or A572	50
Web Members (Vertical and Diagonal)	Hollow Structural Section	A500 grade B or C	46 or 50 (rectangular)
Gusset Plates	Plates	A36 or A572	36 or 50

nels. The channels were placed toe-to-toe, welded with separator plates to form a tubular shape. Later projects used hollow structural sections (HSS) for vertical and diagonal members.

Today, the most common trusses are designed with W10 chords and HSS web members (verticals and diagonals) connected with gusset plates. The chords have a minimum width of 6 in., required to ensure adequate plank bearing during construction. The smallest chords are generally W10x33 and the smallest web members are generally HSS4x4x1/4. The gusset plates are usually 1/2-in. thick.

The trusses are manufactured with camber to compensate for dead load. They are transported to the site, stored, and then erected, generally in one piece. Table 1.1 is a material guide for steel member selection. Other materials, such as A913, may be available (see AISC Manual, Part 2).

The plank is connected to the chords with weld plates to ensure temporary stability during erection. Then, shear stud connections are welded to the chords, reinforcing bars are placed in the joints, and grout is placed. When the grout cures, a permanent connection is achieved through the

welded studs as illustrated in Fig. 1.2. Alternatively, guying or braces may also be used for temporary stability during construction.

The precast plank is commonly manufactured with 4,000 psi concrete. The grout commonly has 1,800 psi compressive strength and normally is a 3:1 mixture of sand and Portland cement. The amount of water used is a function of the method used to place the grout, but will generally result in a wet mix so joints can be easily filled. Rarely is grout strength required in excess of 2,000 psi. The grout material is normally supplied and placed by the precast erector.

1.3 Framing Layout

Fig. 1.3 shows the photo of a 12-story staggered-truss apartment building located in the Northeast United States. Its typical floor plan is shown in Fig. 1.4. This apartment building will be used as an example to explain the design and construction of staggered-truss-framed structures throughout this design guide. The floor system of this 12-story proj-

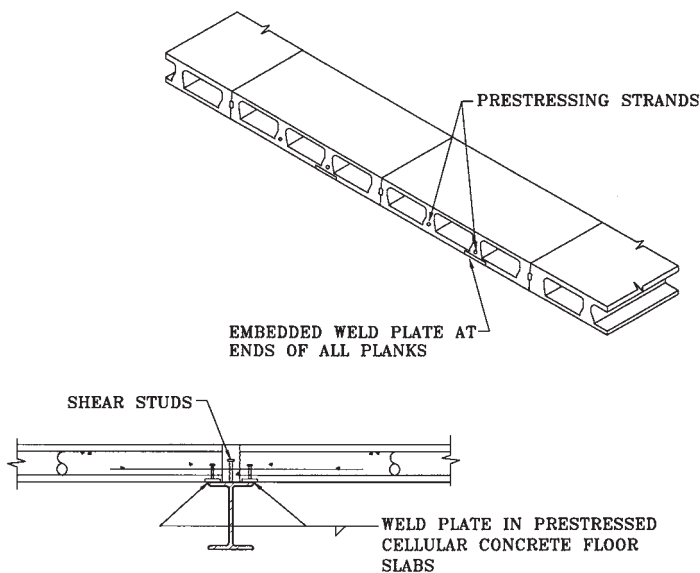

Fig. 1.2 Concrete plank floor system.



Fig. 1.3 Staggered truss apartment building.

ect utilizes 10-in.-thick precast concrete plank. The stairs and elevator openings are framed with steel beams. The columns are oriented with the strong axis parallel to the short building direction. There are no interior columns on truss bents; only spandrel columns exist. There are interior columns on conventionally framed bents.

Moment frames are used along the long direction of the building, while staggered trusses and moment frames are used in the short direction.

Two different truss types are shown on the plan, namely trusses T1 and T2. Fig. 1.5 shows truss T1B and Fig. 1.6 shows truss T2C. Truss T1B is Truss Type 1 located on grid line B, and T2C is Truss Type 2 located on grid line C. The truss layout is always Truss Type 1 next to Type 2 to minimize the potential for staggered truss layout errors. Each truss is shown in elevation in order to identify member sizes and special conditions, such as Vierendeel panels. Any special forces or reactions can be shown on the elevations where they occur. The structural steel fabricator/detailer is provided with an explicit drawing for piece-mark identification. Camber requirements should also be shown on the elevations.

Table 1.2 shows the lateral forces calculated for the building. For this building, which is located in a low-seismic zone, wind loads on the wide direction are larger than seismic forces, and seismic forces are larger in the narrow direction. So that no special detailing for seismic forces would be required, a seismic response modification factor R of 3 was used in the seismic force calculations. The distributed gravity loads of the building are listed below, where plate loads are used for camber calculations.

Dead Loads

10" precast hollow core plank	75 psf
Leveling compound	5
Structural steel	5
Partitions	12
Dead Loads	97 psf

Plate Loads

10" precast hollow core plank	75 psf
Structural steel	5
Plate Loads	80 psf

Live Loads 40 psf

Wall Loads

Brick	40 psf
Studs	3
Sheet rock	3
Insulation	2
Wall Loads	48 psf

The loads listed above are used in the calculations that follow.

1.4 Responsibilities

The responsibilities of the various parties to the contract are normally as given on the AISC *Code of Standard Practice for Steel Buildings and Bridges*. All special conditions should be explicitly shown on the structural drawings.

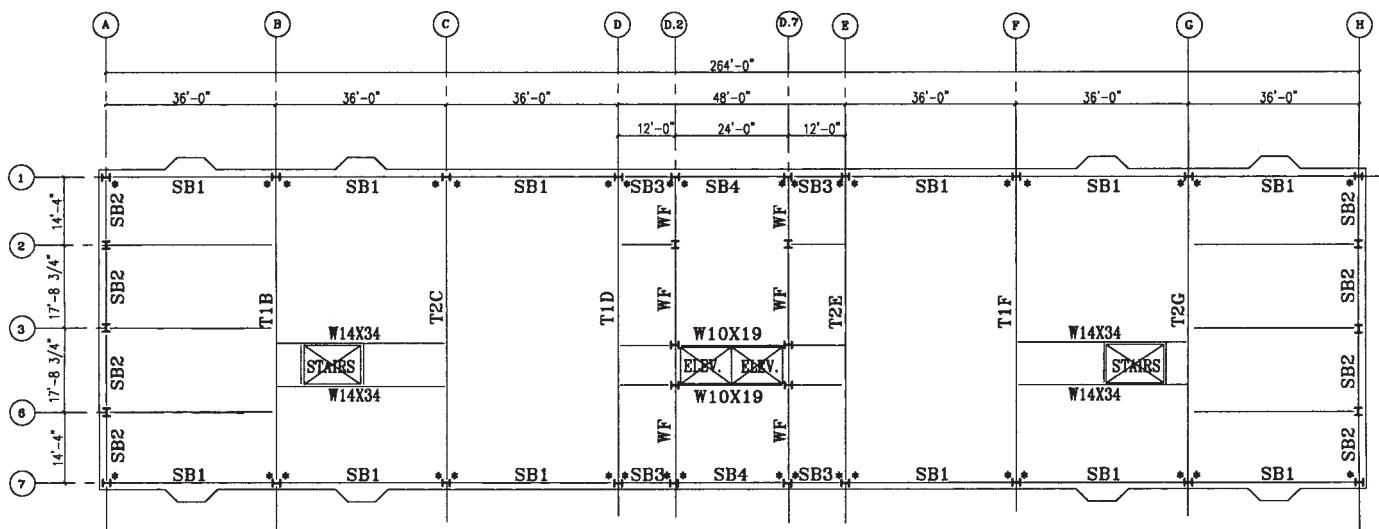

Fig. 1.4 Typical floor framing plan. Note: * indicates moment connections.

Table 1.2 Wind and Seismic Forces (All Loads are Service Loads)						
	WIND (ON WIDE DIRECTION)			SEISMIC (BOTH DIRECTIONS)		
	Lateral Load	Story Shear	Φ_h	Lateral Load Service	Story Shear	Φ_h
Floor	V_j (kips)	V_w (kips)	(%)	V_j (kips)	V_w (kips)	(%)
Roof	107	107	9%	83	83	13%
12	105	212	18%	90	173	26%
11	103	315	27%	82	255	39%
10	103	418	36%	78	333	51%
9	103	521	45%	65	398	61%
8	98	619	54%	58	456	70%
7	96	715	62%	52	508	78%
6	93	808	70%	44	552	85%
5	91	899	78%	39	591	91%
4	86	985	86%	29	620	95%
3	84	1069	93%	21	641	98%
2	79	1148	100%	11	652	100%
Ground						

1.5 Design Methodology

The design of a staggered-truss frame is done in stages. After a general framing layout is completed, gravity, wind, and seismic loads are established. Manual calculations and member sizing normally precede the final computer analysis and review. For manual calculations, gravity and lateral loads are needed and the member sizes are then obtained through vertical tabulation.

The design methodology presented in this design guide is intended to save time by solving a typical truss only once for gravity loads and lateral loads, then using coefficients to obtain forces for all other trusses. The method of coefficients is suitable for staggered trusses because of the repetition of the truss geometry and because of the “racking” or shearing behavior of trusses under lateral loads. This is similar to normalizing the results to the “design truss”.

Approximate analysis of structures is needed even in today’s high-tech computer world. At least three significant reasons are noted for the need for preliminary analysis as following:

1. It provides the basis for selecting preliminary member sizes, which are needed for final computer input and verification.
2. It provides a first method for computing different designs and selecting the preferred one.
3. It provides an independent method for checking the reports from a computer output.

Theoretically, staggered-truss frames are treated as structurally determinate, pin-jointed frames. As such, it is assumed that no moment is transmitted between members across the joints. However, the chords of staggered trusses

are continuous members that do transmit moment, and some moment is always transmitted through the connections of the web members.

The typical staggered-truss geometry is that of a “Pratt truss” with diagonal members intentionally arranged to be in tension when gravity loads are applied. Other geometries, however, may be possible.

1.6 Design Presentation

The structural drawings normally include floor framing plans, structural sections, and details. Also, structural notes and specifications are part of the contract documents. Floor plans include truss and column layout, stairs and elevators, dimensions, beams, girders and columns, floor openings, section and detail marks. A column schedule indicates column loads, column sizes, location of column splices, and sizes of column base plates.

The diaphragm plan and its chord forces and shear connectors with the corresponding forces must be shown. It is also important that the plan clearly indicate what items are the responsibilities of the steel fabricator or the plank manufacturer. Coordination between the two contractors is critical, particularly for such details as weld plate location over stiffeners, plank camber, plank bearing supports, and clearances for stud welding. Coordination meetings can be particularly helpful at the shop drawing phase to properly locate plank embedded items.

In seismic areas, the drawings must also indicate the Building Category, Seismic Zone, Soil Seismic Factor, Importance Factor, required value of R , and Lateral Load Resisting System.

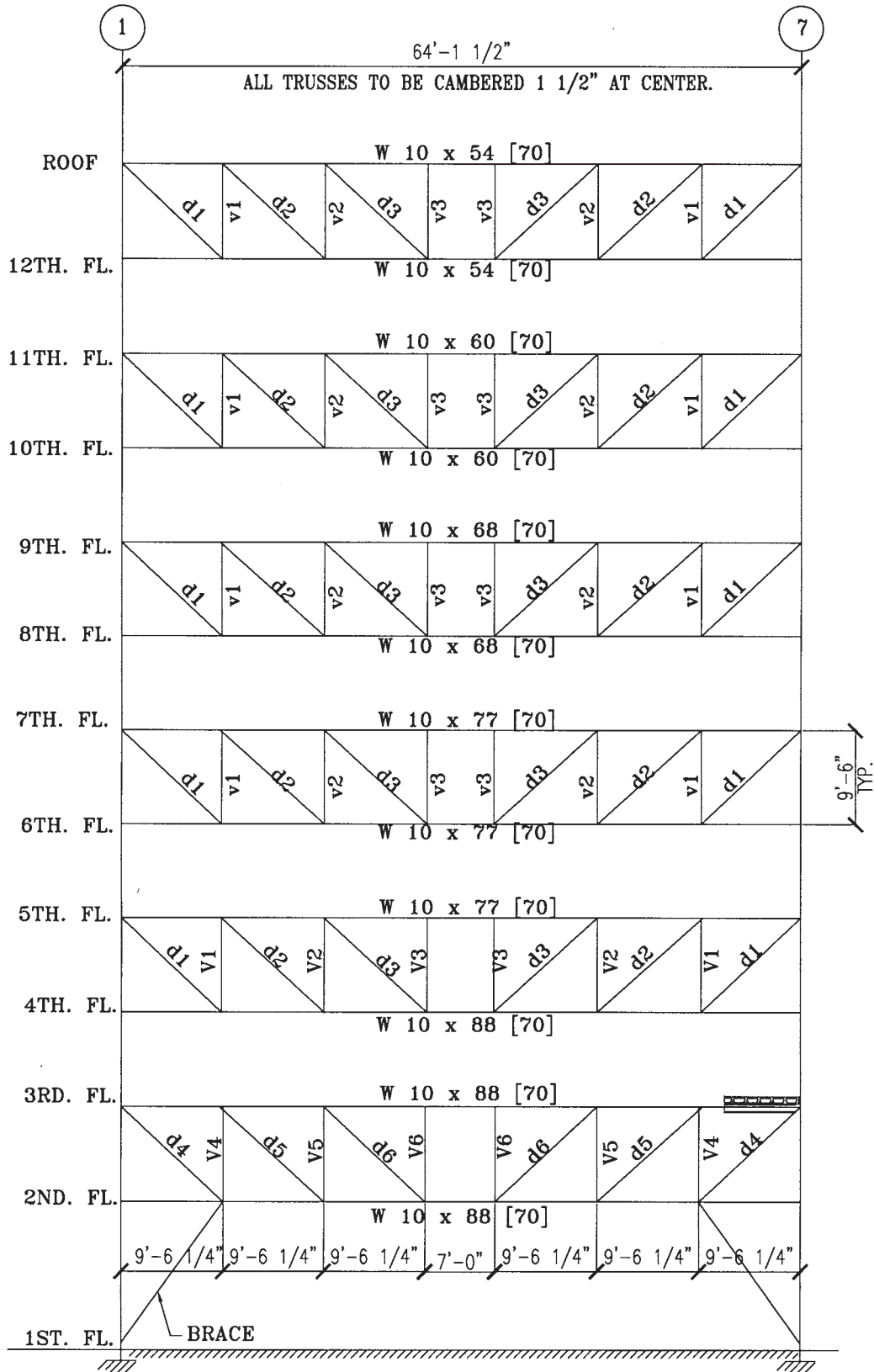

Fig. 1.5 Staggered truss type TIB. Note: [] indicates number of composite studs (3/4" dia., 6" long, equally spaced).

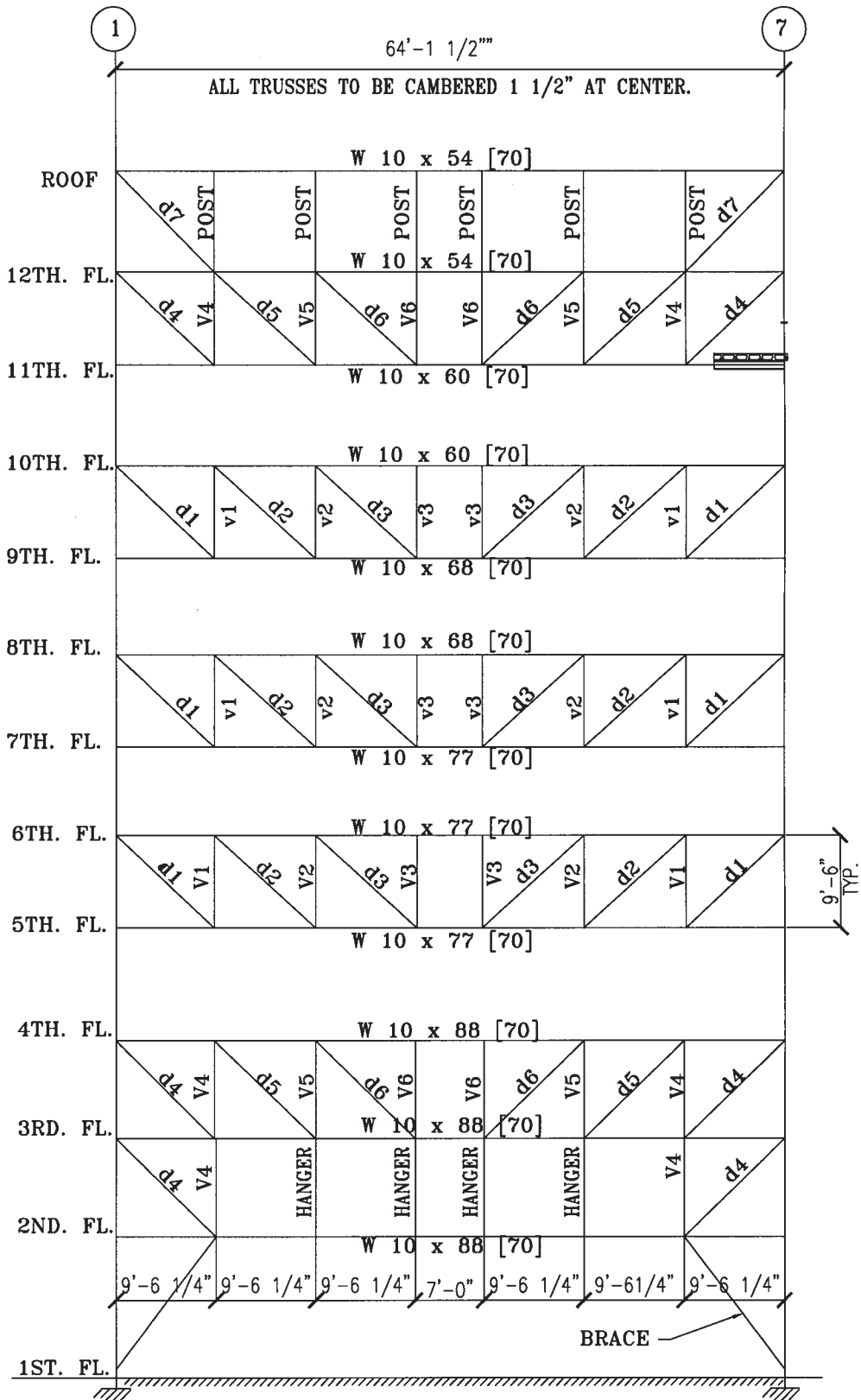

Fig. 1.6 Staggered truss type T2C. Note: [] indicates number of composite studs (3/4" dia., 6" long, equally spaced).

Chapter 2

DIAPHRAGM ACTION WITH HOLLOW-CORE SLABS

2.1 General Information

It is advisable to start the hand calculations for a staggered-truss building with the design of the diaphragms. In a staggered-truss building, the diaphragms function significantly different from diaphragms in other buildings because they receive the lateral loads from the staggered trusses and transmit them from truss to truss. The design issues in a hollow-core diaphragm are stiffness, strength, and ductility, as well as the design of the connections required to unload the lateral forces from the diaphragm to the lateral-resisting elements. The *PCI Manual for the Design of Hollow Core Slabs* (PCI, 1998) provides basic design criteria for plank floors and diaphragms.

Some elements of the diaphragm design may be delegated to the hollow core slab supplier. However, only the engineer of record is in the position to know all the parameters involved in generating the lateral loads. If any design responsibility is delegated to the plank supplier, the location and magnitude of the lateral loads applied to the diaphragm and the location and magnitude of forces to be transmitted to lateral-resisting elements must be specified.

An additional consideration in detailing diaphragms is the need for structural integrity. ACI 318 Section 16.5 provides the minimum requirements to satisfy structural integrity. The fundamental requirement is to provide a complete load path from any point in a structure to the foundation. In staggered-truss buildings all the lateral loads are transferred from truss to truss at each floor. The integrity of each floor diaphragm is therefore significant in the lateral load resistance of the staggered-truss building.

2.2 Distribution of Lateral Forces

The distribution of lateral forces to the trusses is a structurally indeterminate problem, which means that deformation compatibility must be considered. Concrete diaphragms are generally considered to be rigid. Analysis of flexible diaphragms is more complex than that of rigid diaphragms. However, for most common buildings subject to wind forces and low-seismic risk areas, the assumption of rigid diaphragms is reasonable. If flexible diaphragms are to be analyzed, the use of computer programs with plate-element options is recommended.

For the example shown in this design guide, a rigid diaphragm is assumed for the purpose of hand calculations and for simplicity. This assumption remains acceptable as long as the diaphragm lateral deformations are appropriately limited. One way to ensure this is to limit the

diaphragm aspect ratio and by detailing it such that it remains elastic under applied loads. From Smith and Coull (1991), the lateral loads are distributed by the diaphragm to trusses as follows:

$$V_i = V_s + V_{\text{TORS}} \quad (2-1)$$

where

$$\begin{aligned} V_i &= \text{truss shear due to lateral loads} \\ V_s &= \text{the translation component of shear} \\ &= V_w \times GA_i / \Sigma GA_i \end{aligned} \quad (2-2)$$

$$\begin{aligned} V_{\text{TORS}} &= \text{the torsion component of shear} \\ &= V_w \times e \times \bar{x}_i GA_i / GJ \end{aligned} \quad (2-3)$$

where

- GA_i = Shear rigidity of truss
- ΣGA_i = Building translation shear rigidity
- GJ = Building torsion shear rigidity
- e = Load eccentricity
- \bar{x}_i = Truss coordinate (referenced to the center of rigidity (CR))
- V_w = Story shear due to lateral loads (see Table 1.2)

Smith and Coull (1991) provide expressions for story shear deformations for a single brace as (Fig. 2.1):

$$\Delta = \frac{V}{E} \left(\frac{d^3}{L^2 A_d} + \frac{L}{A_g} \right) \quad (2-4)$$

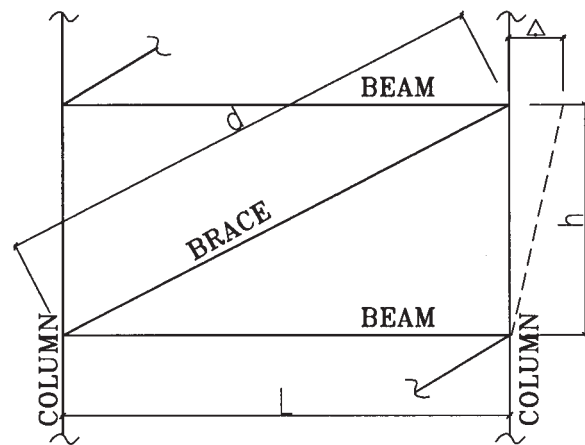

Fig. 2.1 Story shear deformation for single brace.

where

- V = shear force applied to the brace
- E = modulus of elasticity
- d = length of the diagonal
- L = length between vertical members
- A_d = sectional area of the diagonal
- A_g = sectional area of the upper girder

The shear rigidity GA is then computed as:

$$GA = \frac{Vh}{\Delta} = \frac{Eh}{d^3 / (L^2 A_d) + L / A_g} \quad (2-5)$$

where h is the story height. The overall truss shear rigidity is the sum of the shear rigidities of all the brace panels in that truss. The reader may use similar expressions to determine approximate values for GA in buildings where variations in stiffness occur.

The hand calculations are started by finding the center of rigidity, which is defined as the point in the diaphragm about which the diaphragm rotates when subject to lateral loads. The formula for finding the center of rigidity is (Smith and Coull, 1991; Taranath, 1997):

$$x = \frac{\sum x_i GA_i}{\sum GA_i} \quad (2-6)$$

For staggered-truss buildings, the center of rigidity is calculated separately at even floors and odd floors. Assuming that the trusses of the staggered-truss building shown in Figs. 1.5 and 1.6 have approximately equal shear rigidity, GA_i , per truss, the center of rigidity of each floor is calculated as follows (see Fig. 2.2):

Even Floors

Truss	x_i (ft)
T1B	36
T1D	108
T1F	192
<hr/>	<hr/>
$\Sigma x_i =$	336

$x_e = 336/3 = 112'$

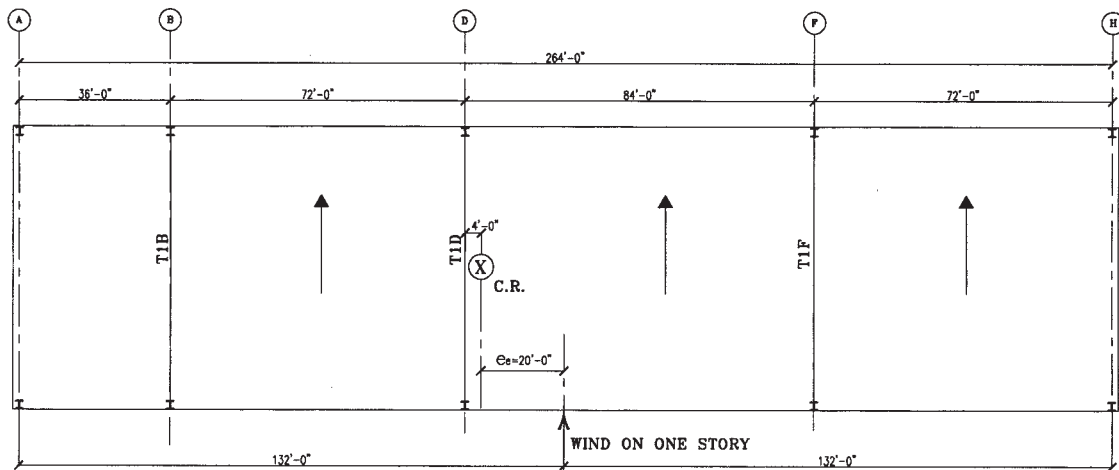

(a)—Even Floor

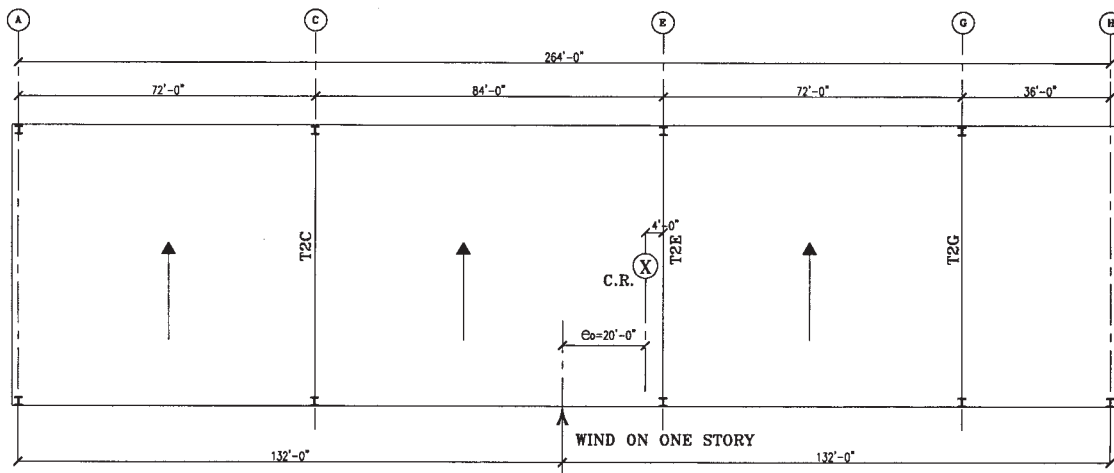

(b)—Odd Floor

Fig. 2.2 Center of rigidity for lateral loads.

where x_e is the center of rigidity for even floors.

Odd Floors

Truss	x_i (ft)
T2C	72
T2E	156
T2G	228
$\Sigma x_i =$	$\overline{456}$

$x_o = 456/3 = 152'$

where x_o is the center of rigidity for odd floors. The load eccentricity is calculated as the distance between the center of rigidity and the location of the applied load.

$$e_e = (264/2) - 112 = 20' \quad \text{even floors}$$

$$e_o = (264/2) - 152 = -20' \quad \text{odd floors}$$

Adding 5% eccentricity for accidental torsion, the final load eccentricity is calculated as follows:

$$e_e = 20 \pm (5\% \times 264)$$

$$= 33.2; 6.8 \text{ ft}$$

$$e_o = -20 \pm (5\% \times 264)$$

$$= -33.2; -6.8 \text{ ft}$$

From this it is clear that for this example even and odd floors are oppositely symmetrical. The base torsion is calculated as the base shear times the eccentricity:

$$T = 1,148 \times 33.2 = 38,114 \text{ ft-k}$$

$$T = 1,148 \times 6.8 = 7,807 \text{ ft-k}$$

where the base shear of 1,148 k is from Table 1.2. The above torsions have plus and minus signs. Again assuming that all trusses have the same shear rigidity GA_i at each floor, the base translation shear component is the same for all trusses:

$$V_s = 1,148/3 = 383 \text{ k}$$

Next, the torsional rigidity GJ is calculated as shown in Tables 2.1 and 2.2 for even floors and odd floors. The torsional shear component varies and is added or subtracted to the translational shear component. The results are summarized in Table 2.3, which is obtained by using Equations 2-1, 2-2, and 2-3. The second-to-last column in Table 2.3 shows the design forces governing the truss design. Note that the design shear for the trusses is based on +5% or -5% eccentricity, where * indicates the eccentricity case that governs. Table 2.3 also shows that the design base shear for trusses T1B and T2G is 335 k, for trusses T1D and T2E is 380 k, and for trusses T1F and T2C is 634 k. We can now proceed with the truss design for lateral loads, but we will first continue to analyze and design the diaphragm.

2.3 Transverse Shear in Diaphragm

Planks are supported on trusses with longitudinal joints perpendicular to the direction of the applied lateral load. To satisfy structural integrity, the diaphragm acts as a deep beam or a tied arch. Tension and compression chords create the flanges, and boundary elements are placed around the openings. The trusses above are considered to act as “drag struts”, engaging the entire length of the diaphragm for transferring shear to the adjacent trusses below (Fig. 2.3).

Truss shear forces calculated in Table 2.3 are used to find the shear and moment diagrams along the diaphragm of the bottom floor as shown in Fig. 2.4. Two torsion cases (+5% and -5% additional eccentricities) are considered. The required shear strength of the diaphragm is calculated as follows:

$$V_u = 1.7 \times \phi_h \times V \times 0.75$$

$$= 1.7 \times 1.0 \times 335 \times 0.75$$

$$= 427 \text{ k}$$

where ϕ_h is the story shear adjustment coefficient (see Table 1.2 and Section 3.5 of this design guide), 0.75 is applied for wind or seismic loads, and $V = 335 \text{ k}$ is the maximum shear force in the diaphragm as indicated in Fig. 2.4. The provided design shear strength is calculated per ACI 318 Section 11.3.

$$\phi V_n = \phi (V_c + V_s)$$

$$\phi V_c = \phi \times 2 \sqrt{f'_c} b d$$

$$= 0.85 \times 2 \times \sqrt{4000} \times 6 \times (0.8 \times 64 \times 12)$$

$$= 396 \text{ k}$$

where an effective thickness of 6 in. is used for the 10-in.-thick hollow core planks, and the effective depth of the beam is assumed to be 80% of the total depth.

$$\phi V_s = \phi A_{VF} f_y \mu$$

where A_{VF} is the shear friction reinforcement and $\mu = 1.4$ is the coefficient of friction. Assuming one #4 steel bar is used along each joint between any two planks,

$$\text{No. of planks} = 64'/8' = 8 \text{ planks}$$

$$\text{No. of joints} = 8 - 1 = 7 \text{ joints}$$

$$A_{VF} = 0.2 \times 7 = 1.4 \text{ in}^2$$

$$\phi V_s = 0.85 \times 1.4 \times 60 \times 1.4 = 100 \text{ k}$$

$$\phi V_n = 396 + 100 = 496 \text{ k} > 427 \text{ k}$$

(O.K.)

Rev.
12/1/02

Table 2.1 Torsional Rigidity, Even Floors		
Truss	\bar{x}_i	\bar{x}_i^2
T1B	-76	5,776
T1D	-4	16
T1F	80	6400
$\Sigma=12,192 \text{ ft}^2$		

Table 2.2 Torsional Rigidity, Odd Floors		
Truss	\bar{x}_i	\bar{x}_i^2
T2C	-80	6,400
T2E	4	16
T2G	76	5,776
$\Sigma=12,192 \text{ ft}^2$		

Table 2.3 Shear Force in Each Truss due to Lateral Loads (Bottom Floor)								
Truss	\bar{x}_i	V_s	$T=38,114 \text{ (ft-k)}$		$T=7,807 \text{ (ft-k)}$		Design Shear $V \text{ (kips)}$	Φ_{ecc}
			V_{TORS}	V_i	V_{TORS}	V_i		
T1B	-76	383	-238	145	-48	335*	335	1.00
T1D	-4	383	-13	370	-3	380*	380	1.13
T1F	80	383	251	634*	51	434	634	1.89
T2C	-80	383	251	634*	51	434	634	1.89
T2E	4	383	-13	370	-3	380*	380	1.13
T2G	76	383	-238	145	-48	335*	335	1.00

2.4 Diaphragm Chords

The perimeter steel beams are used as diaphragm chords. The chord forces are calculated approximately as follows:

$$H = M/D \quad (2-7)$$

where

- H = chord tension or compression force
- M = moment applied to the diaphragm
- D = depth of the diaphragm

The plank to spandrel beam connection must be adequate to transfer this force from the location of zero moment to the location of maximum moment. Thus observing the moment diagrams in Fig. 2.4, the following chord forces and shear flows needed for the plank-to-spandrel connection design are calculated:

With +5% additional eccentricity:

$$H = 5,223 / 64 \times 0.75 = 61 \text{ k}$$

$$f_H = 61 / 72 = 0.85 \text{ k/ft}$$

$$H = 5,223 / 64 \times 0.75 = 61 \text{ k}$$

$$f_H = 61 / 17 = 3.59 \text{ k/ft}$$

$$H = 12,024 / 64 \times 0.75 = 141 \text{ k}$$

$$f_H = 141 / 103 = 1.37 \text{ k/ft}$$

$$f_H = 141 / 72 = 1.96 \text{ k/ft}$$

where constant 0.75 is applied for wind or seismic loads. The calculated shear flows, f_H , are shown in Fig. 2.4(a). For -5% additional eccentricity, similar calculations are conducted and the results are shown in Fig. 2.4(b). The shear flows of the two cases are combined in Fig. 2.4(c),

Rev.
12/1/02

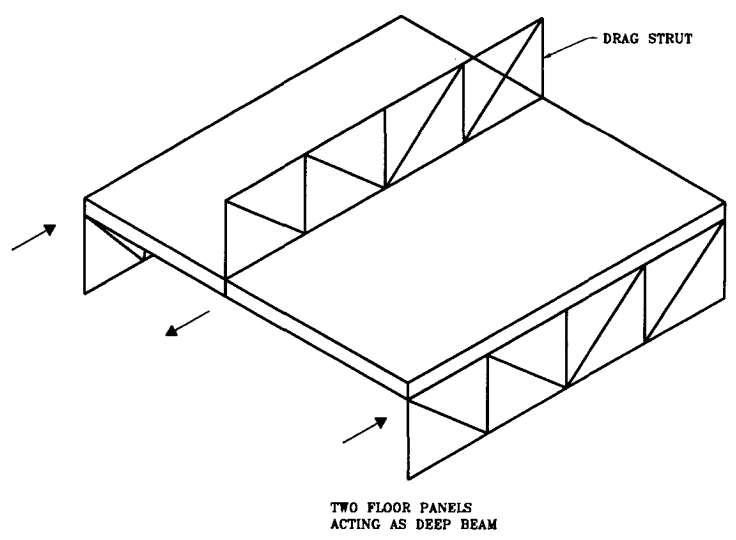
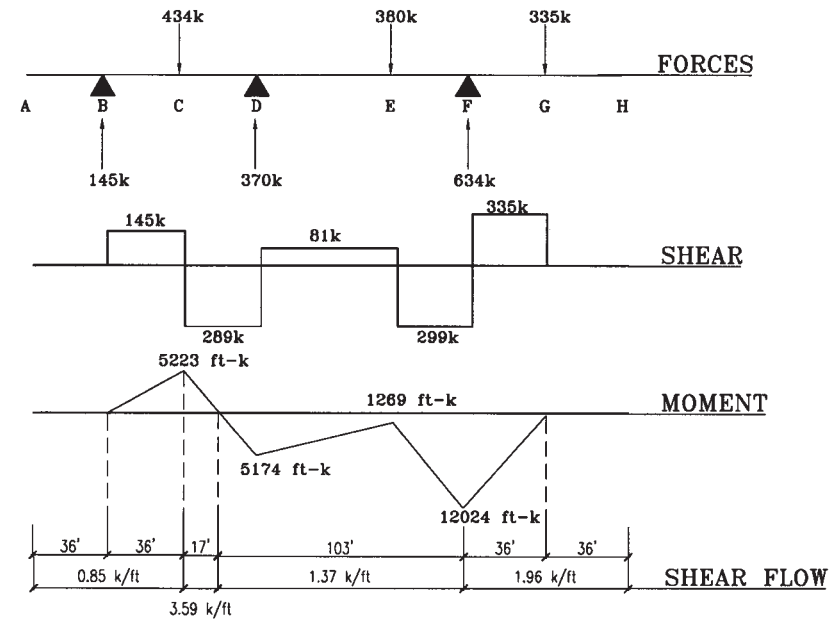

Fig. 2.3 Diaphragm acting as a deep beam.

where a value with * indicates the larger shear flow that governs. These shear forces and shear flows due to service loads on the bottom floor are then multiplied by the height adjustment factors for story shear to obtain the final design of the diaphragms up to the height of the building as shown in the table in Fig. 2.5. The table is drawn on the structural drawings and is included as part of the construction contract documents. Forces given on structural drawings are generally computed from service loads. In case factored forces are to be given on structural drawings, they must be clearly specified.

The perimeter steel beams must be designed to support the gravity loads in addition to the chord axial forces, H .

The connections of the beams to the columns must develop these forces (H). The plank connections to the spandrel beams must be adequate to transfer the shear flow, $\frac{f_v}{2}$. The plank connections to the spandrel are usually made by shear plates embedded in the plank and welded to the beams (Fig. 1.2 and Fig. 2.6). Where required, the strength of plank embedded connections is proven by tests, usually available from the plank manufacturers. All forces must be shown on the design drawings. The final design of the diaphragm is shown in Fig. 2.5.



(a) **CASE 1 - WITH +5% ACCIDENTAL ECCENTRICITY**

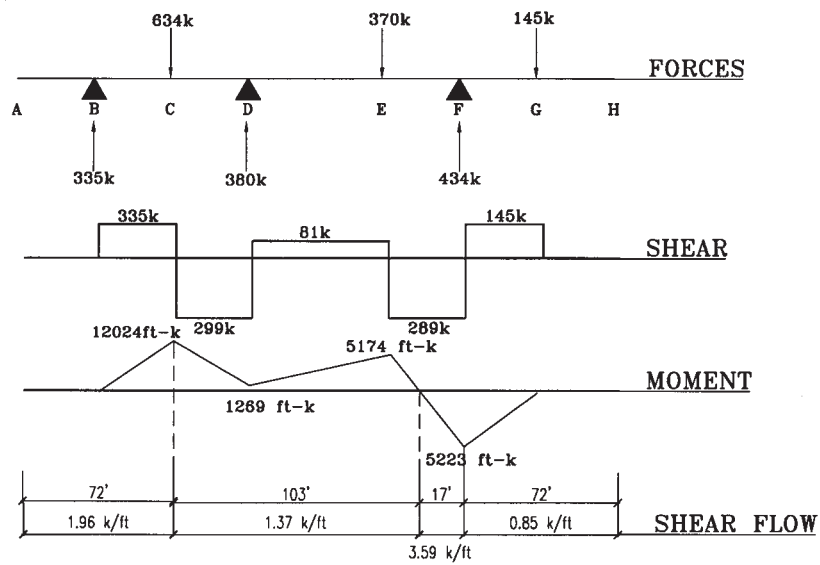

(b) **CASE 2 - WITH -5% ACCIDENTAL ECCENTRICITY**

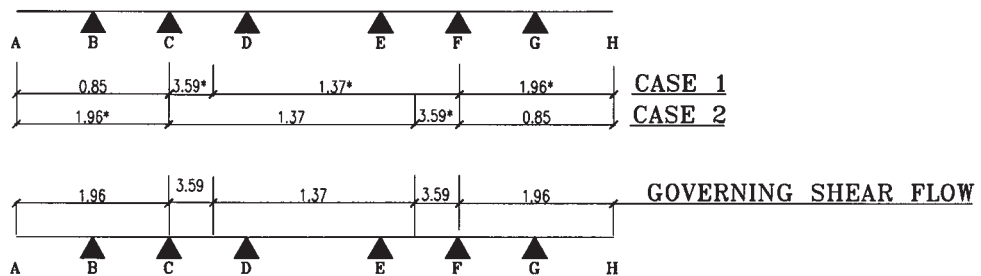

(c) **SUMMARY OF SHEAR FLOWS**

Fig. 2.4 Diaphragm shear force, moment, and shear flow (2nd floor).

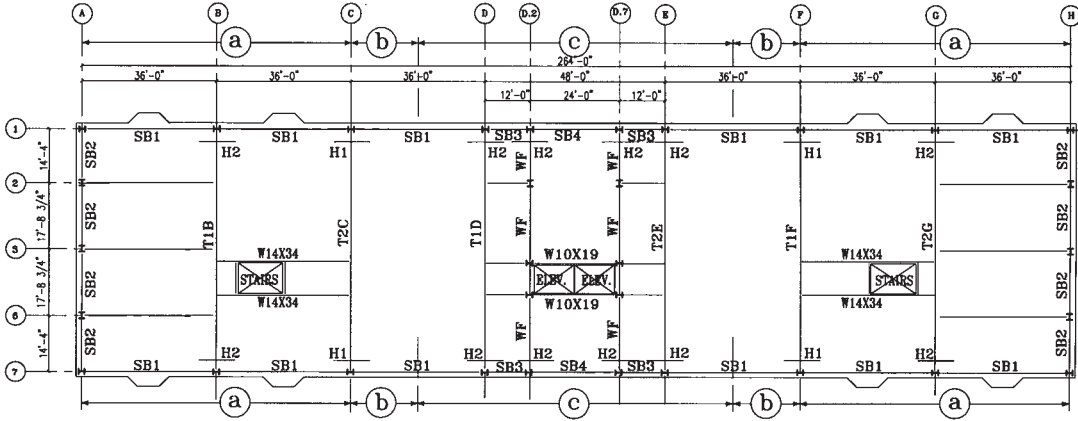

	ϕ_h	H(kips)		f_H (k/ft)		
		H1	H2	(a)	(b)	(c)
ROOF	9%	13	5	.18	.32	.12
12th	18	25	11	.35	.65	.25
11th	27	38	16	.53	.97	.37
10th	36	51	22	.70	1.29	.49
9th	45	63	27	.88	1.62	.62
8th	54	76	33	1.06	1.94	.74
7th	62	87	38	1.21	2.22	.85
6th	70	99	43	1.37	2.51	.96
5th	78	110	48	1.53	2.80	1.07
4th	86	121	52	1.68	3.09	1.18
3rd	93	131	57	1.82	3.34	1.27
2nd	100	141	61	1.96	3.59	1.37
GROUND						

NOTE: ϕ_h VALUES ARE FROM TABLE 1.2

Fig. 2.5 Diaphragm design.

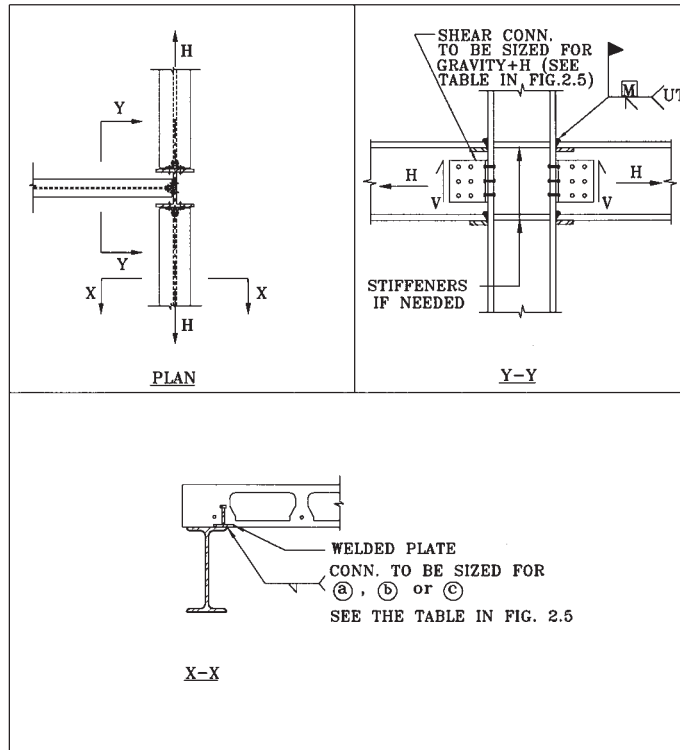

Fig. 2.6 Detail for load transfer from diaphragm to spandrel beams.

Chapter 3

DESIGN OF TRUSS MEMBERS

3.1 Hand and Computer Calculations

The structural design of truss members normally begins with hand calculations, which are considered to be approximate and prerequisite to more detailed computer calculations. Computer analyses can be either two or three dimensional using stiffness matrix methods with or without member sizing. Some programs assume a rigid diaphragm and the lateral loads are distributed based on the relative stiffness of the trusses. In other programs, the stiffness of the diaphragm can be modeled with plate elements.

For truss design, hand and computer calculations have both advantages and disadvantages. For symmetrical buildings, 2-D analysis and design is sufficient and adequate. For non-symmetrical structures, 3-D analyses in combination with 2-D reviews are preferred. The major advantage of a 2-D analysis and design is saving in time. It is fast to model and to evaluate the design results.

Hand calculations typically ignore secondary effects such as moment transmission through joints, which may appear to produce unconservative results. However, it is worthwhile to remember that some ductile but self-limiting deformations are allowed and should be accepted.

3.2 Live Load Reduction

Most building codes relate the live load reduction to the tributary area each member supports. For staggered trusses this requirement creates a certain difficulty since the tributary areas supported by its vertical and diagonal members vary. Some engineers consider the entire truss to be a single member and thus use the same maximum live load reduction allowed by code for all the truss members. Others calculate the live load reduction on the basis of the equivalent tributary area each member of the truss supports. Clearly, member d1 in Fig. 1.5, which carries a heavy load, supports an equivalent tributary area larger than that of member d3, which carries a light load. Thus, assuming that web members support equivalent floor areas, the following tributary area calculations apply:

$$\begin{aligned} \text{d1: } TA &= (7/2 + 9.5 \times 2 + 9.5/2) 36 \times 2 \\ &= 1,960 \text{ ft}^2 \\ \text{d2: } TA &= (7/2 + 9.5 + 9.5/2) 36 \times 2 \\ &= 1,278 \text{ ft}^2 \\ \text{d3: } TA &= (7/2 + 9.5/2) 36 \times 2 \\ &= 594 \text{ ft}^2 \end{aligned}$$

These tributary areas can also be verified from the member loads as follows. Thus, considering the entire truss T1B, the tributary area is:

$$TA = 64 \times 36 \times 2 = 4,608 \text{ ft}^2$$

The total dead load supported by the truss is:

$$W_{DL} = 4,608 \times 97 \text{ psf} = 446.7 \text{ k}$$

For member d1:

$$\begin{aligned} \text{Axial force } T &= 380 \text{ k} \times 97 / (97 + 40) \\ &= 269 \text{ k} \text{ (see Fig. 3.3)} \end{aligned}$$

$$\begin{aligned} \text{Vertical component of } T &= 269 / \sqrt{2} \\ &= 190 \text{ k} \end{aligned}$$

$$TA = 190 / 446.7 \times 4,608 = 1,960 \text{ ft}^2$$

This tributary area is the same as the one calculated previously. Similar calculations yield the tributary areas for members d2 and d3.

3.3 Gravity Loads

Fig. 3.1 shows a one-story truss with applied gravity loads. The members are assumed to intersect at one point. The vertical and diagonal members are assumed to be hinged at each end. The top and bottom chords are continuous beams and only hinged at the ends connected to the columns. Because a diagonal member is not allowed to be placed in the Vierendeel panel where a corridor is located, the chords cannot be modeled as axial-force members. Otherwise, the truss would be unstable. For hand calculation purposes, it

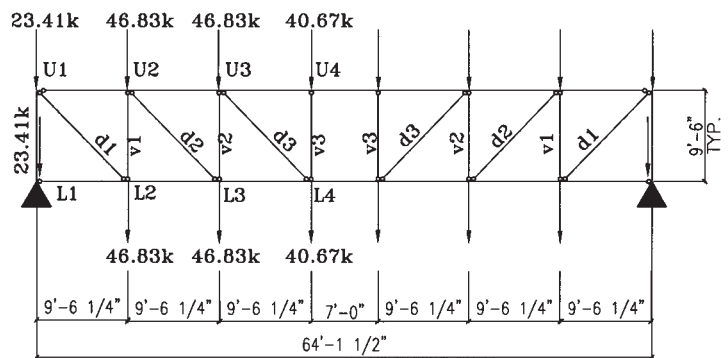

Fig. 3.1 Analysis of truss T1B—gravity loads.

is customary to convert the uniform loads to concentrated loads applied at each joint. It will be shown later that shear forces in the chords have to be included in the hand calculations when lateral loads are applied. The chords are subject to bending and shear, but the vertical and diagonal members are not because they are two-force members.

The truss model shown is "statically indeterminate". The truss can certainly be analyzed using a computer. However, reasonably accurate results can also be obtained through hand calculations. For gravity loads, the shear force in the top or bottom chord in the Vierendeel panel vanishes because of symmetry. The shear forces in the chords of other panels are very small and can be neglected. Based on this assumption, the truss becomes statically determinate and the member forces can be calculated directly by hand calculations from statics. The best way to start the calculations is by finding the reactions at the supports. After the reactions are determined, there are two different options for the further procedure.

- The method of joints.
- The method of sections.

The reader is referred to Hibbeler (1998) or Hsieh (1998) or any other statics textbook for in-depth discussion of each method. Each method can resolve the truss quickly and provide the correct solution. Fig. 3.2 shows the truss solution using the method of joints. It is best to progress the solution in the following joint order: L1, U1, L2, U2, etc. The following calculations are made for typical truss T1B subject to full service gravity loads:

$$w = (97 \text{ psf} + 40 \text{ psf}) \times 36' = 4.93 \text{ k/ft}$$

$$P_1 = 4.93 \times 9.5 / 2 = 23.41 \text{ k}$$

$$P_2 = 4.93 \times 9.5' = 46.83 \text{ k}$$

$$P_3 = 4.93 \times (9.5 + 7)/2 = 40.67 \text{ k}$$

The above concentrated loads are applied at the top and bottom joints as shown in Fig. 3.1. The reactions at supports are:

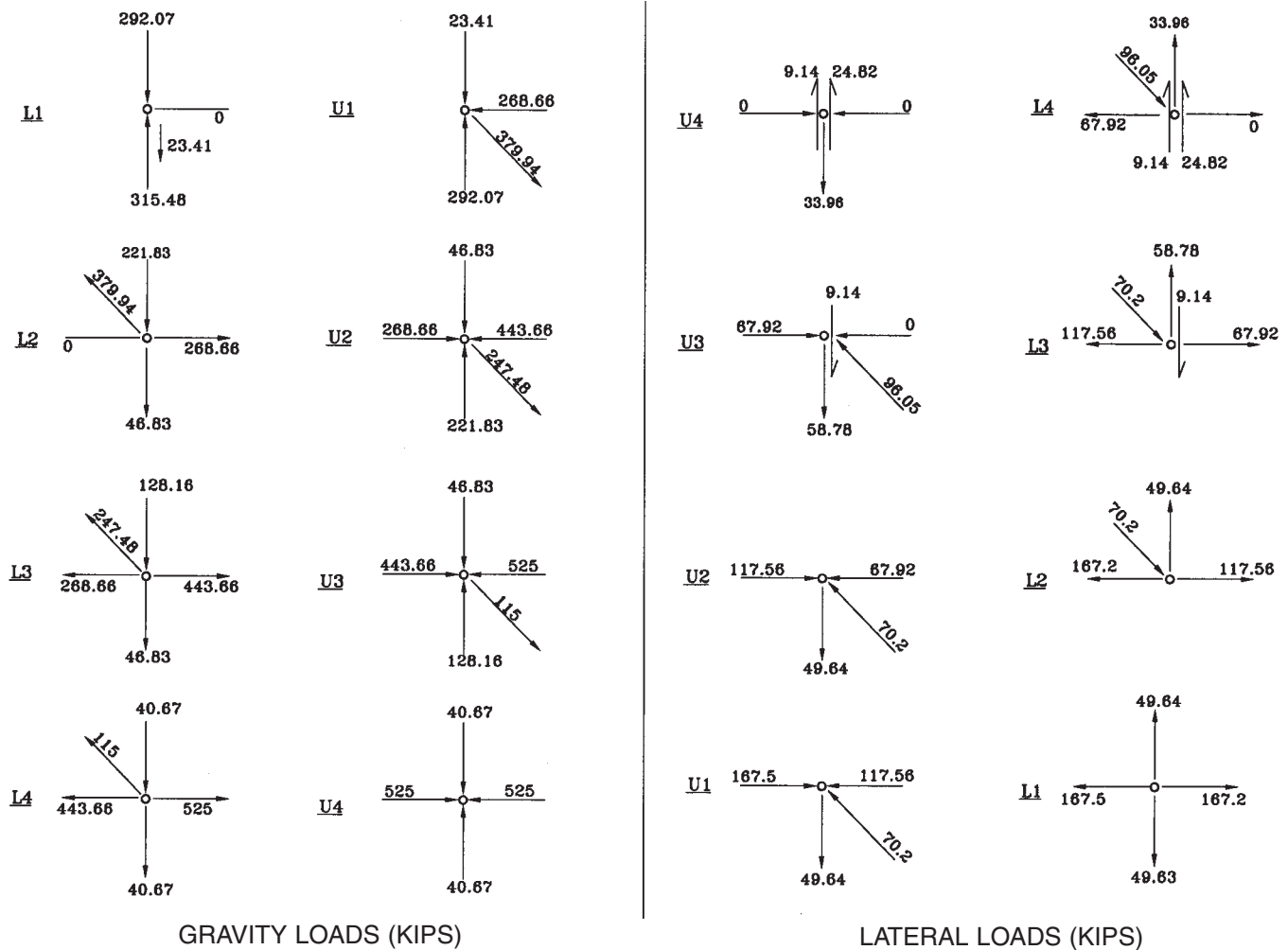

Fig. 3.2 Truss solution—method of joints.

$$R = (23.41 + 46.83 \times 2 + 40.67) \times 2$$

$$= 315.48 \text{ k}$$

The calculations then proceed for each joint as shown in Fig. 3.2. Here shear forces in the chord members are excluded from the calculations because they are assumed zero. The result of all the member forces of the typical truss due to service gravity loads is summarized in Fig. 3.3.

3.4 Lateral Loads

The allocation of lateral loads to each individual truss is done by the diaphragm based on the truss relative stiffness and its location on the plan. Once the member forces due to lateral loads are calculated, they are combined with the gravity loads to obtain the design-loading envelope. The member sizes are then selected to ensure adequate strength.

Fig. 3.4 shows the member forces due to design shear of 335 kips, which was computed in Table 2.3 for truss T1B of the bottom floor. Because the truss is anti-symmetrical about its centerline for this load case, the horizontal reaction H at each support is 167.5 kips. Alternatively, the floor diaphragm may distribute the horizontal shear force uniformly along the length of the top and bottom chords of the truss, reducing the axial forces in these chords. The vertical reaction at each support is:

$$R = (167.5 \times 2 \times 9.5) / 64.125 = 49.63 \text{ k}$$

The moment and the axial force at midspan of each chord in the Vierendeel panel are both zero because of geometrical anti-symmetry. Considering half of the truss as a free body and assuming the same shear force in the top and bottom chords of the Vierendeel panel, the shear force can be calculated as:

$$V = 1 / 2 \times (167.5 \times 9.5) / 32.06$$

$$= 24.82 \text{ k}$$

The chord end moment at joint U4 is equal to the shear times half the panel length:

$$M = 24.82 \times 7 / 2 = 86.87 \text{ ft-k}$$

This end moment is also applied to the chord adjacent to the Vierendeel panel. Assume the moment at the other end of this chord is zero, the shear force in the member can then be calculated as:

$$V = (86.87 + 0) / 9.5 = 9.14 \text{ k}$$

This shear force is indicated in Fig. 3.4. It can further be assumed that the chord moments in the remaining panels

are all zero and thus the chord shear forces are also zero in these panels. Now we can proceed to find all the member forces using the method of joints in the following order: U4, L4, U3, L3, etc. The calculations are shown in Fig. 3.2. The above assumptions of zero moments in the chord members are justified by comparing the results with those from the computer analysis. Fig. 3.4 shows the truss solution of the bottom floor due to service lateral loads. Note that while diagonals d_1 and d_2 have the same member force, the member force in diagonal d_3 is larger because of the shear force in that panel.

To verify these hand calculation results, the computer analysis results due to gravity and lateral loads are included in Fig. 3.5 and Fig. 3.6, respectively. The results are very close to those from hand calculations.

3.5 Load Coefficients

Once the member forces have been calculated for a typical truss, the design forces are computed for other trusses using load coefficients. Load factors are then applied per LRFD requirements.

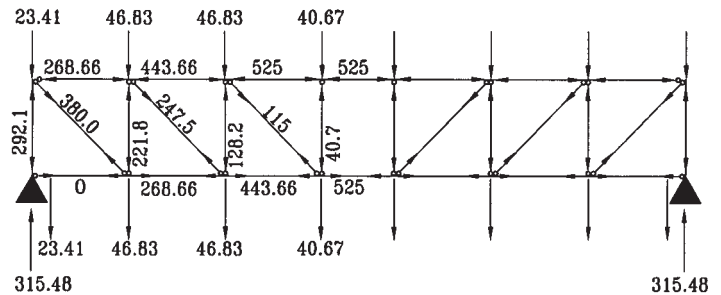

Fig. 3.3 Member forces of truss T1B due to gravity loads (kips).

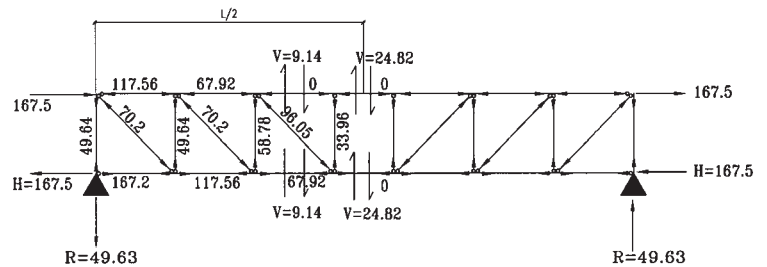

Fig. 3.4 Member forces of truss T1B (bottom floor) due to lateral loads (kips).

Notes: 1. Chord axial forces shown are actually in the concrete floor diaphragm.

2. Lateral forces are conservatively applied as concentrated loads at each end. Optionally loads may also be applied as distributed forces along the chord length.

Load coefficients are calculated as follows:

$$D_i = D_T \times \phi_w \times \phi_L \quad (3-1)$$

$$L_i = L_T \times \phi_w \times \phi_L \quad (3-2)$$

$$W_i = W_T \times \phi_{ecc} \times \phi_h \quad (3-3)$$

$$E_i = E_T \times \phi_{ecc} \times \phi_h \quad (3-4)$$

Subscript *i* indicates the member being designed and subscript *T* indicates the corresponding member of the originally calculated typical truss, i.e., truss T1B. *D, L, W, E* are the dead, live, wind, and earthquake forces, and the load coefficients are defined as follows:

- ϕ_w = Width or tributary area adjustment coefficient
- ϕ_L = Load adjustment coefficient for load factor combinations
- ϕ_{ecc} = Truss eccentricity coefficient
- ϕ_h = Story shear adjustment coefficient

The first two of the above coefficients are applied to gravity loads, and the later two to lateral loads. Load coefficient ϕ_w is applied to a truss whose bay length is different from that of the typical truss. Load coefficient ϕ_L is the ratio of a factored load combination to the full service grav-

ity dead and live loads that are used in the truss member force calculations. The value of ϕ_L varies with load combination cases. Load coefficient ϕ_{ecc} is calculated in Table 2.3, which is used to adjust wind and seismic forces for different design shear forces in different staggered trusses. Load coefficient ϕ_h is computed in Table 1.2 that adjusts story shears at different stories.

Showing below is an example of load coefficient calculations:

$$\begin{aligned} \text{DL} &= 97 \text{ psf, LL} = 40 \text{ psf, and RLL} \\ &= 20 \text{ psf (see Section 1.3)} \\ \phi_w &= 1.0 \text{ for typical truss T1B} \\ &= (36 + 12) / 2 \times (1 / 36) \\ &= 0.67 \text{ for truss T1D (see Fig. 1.4)} \\ \phi_L &\text{ for load combination of } 1.2\text{DL} + 1.6\text{RLL} \\ &= (1.2\text{DL} + 1.6\text{RLL}) / (\text{full service gravity loads}) \\ &= (1.2 \times 97 + 1.6 \times 20) / (97 + 40) \\ &= 1.083 \\ \phi_{ecc} &= 1.0 \text{ for typical truss T1B} \\ &= 380 / 335 = 1.13 \text{ for T1D} \\ &= 634 / 335 = 1.89 \text{ for T1F (see Table 2.4)} \\ \phi_h &= (\text{see Table 1.2 for } \phi_h \text{ value of each story}) \end{aligned}$$

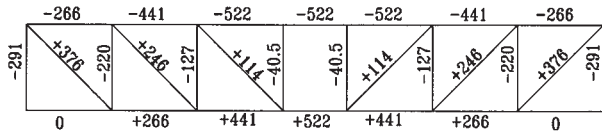

(a) AXIAL FORCE (KIPS)
NOTE: TENSION IS POSITIVE

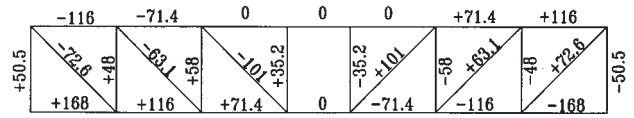

(a) AXIAL FORCE (KIPS)
NOTE: TENSION IS POSITIVE

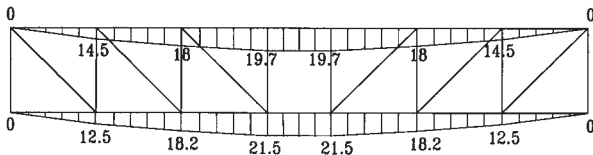

(b) MOMENT (FT-KIP)

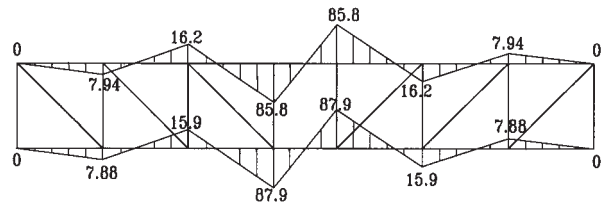

(b) MOMENT (FT-KIP)

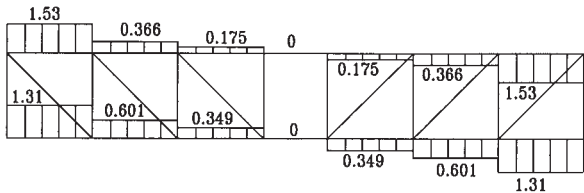

(c) SHEAR (KIPS)

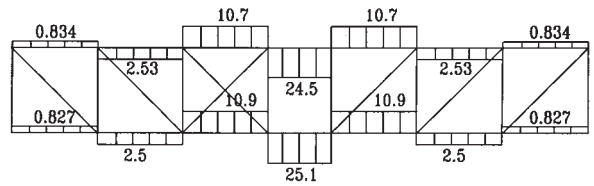

(c) SHEAR (KIPS)

Fig. 3.5 Computer analysis results of truss T1B due to gravity loads.

Fig. 3.6 Computer analysis results of truss T1B of bottom floor due to lateral loads.

3.6 Vertical and Diagonal Members

The detailed calculations for the design of diagonal member d1 in truss T1F of each floor using load coefficients are shown in Table 3.1, where load coefficients ϕ_{L1} , ϕ_{L2} , and ϕ_{L3} are applied to different load combinations. Truss T1F rather than typical truss T1B is intentionally selected as an example here for explanation of how the load coefficients are applied. Five load combinations as specified in ASCE 7 are considered in this table. A 50% live load reduction is used in the design of the diagonal members. Numbers in boldface in the table indicate the load case that governs. The governing tensile axial forces of the diagonal members range from 412 k to 523 k for different floors. HSS 10x6x 1/2 is selected per AISC requirements for all the diagonal members.

3.7 Truss Chords

The designer must investigate carefully all load cases so as to determine which load case governs. For this design example for truss chords, it is found that the load combination of $1.2D + 1.6W + 0.5L$ governs. The steel design must comply with AISC Equation H1-1a.

$$P_u / (\phi P_n) + (8 / 9) \times [M_{ux} / (\phi_b M_{nx})] \leq 1.0$$

where

$$\begin{aligned} \phi &= 0.90 && \text{Tension} \\ &= 0.85 && \text{Compression} \\ \phi_b &= 0.90 && \text{Bending} \end{aligned}$$

Calculations for gravity and wind loads are made separately and then combined.

a. Gravity

It is assumed that the chords are loaded with a uniformly distributed load. Using a 50% live load reduction, the following are calculated for the chords of truss T1F on the second story:

$$\begin{aligned} \phi_w &= 1.0 \text{ for truss T1F} \\ M &= 4.93 \times 9.5^2 / 10 \\ &= 44 \text{ ft-k (member end moments at joints)} \\ P &= 525 \text{ k (from Fig. 3.3)} \end{aligned}$$

$$\begin{aligned} M_u &= \phi_L M \\ &= [(1.2 \times 97 + 0.5 \times 20) / (97 + 40)] \times 44 \\ &= 41 \text{ ft-k} \end{aligned}$$

$$\begin{aligned} P_u &= \phi_L P \\ &= (1.2 \times 97 + 0.5 \times 20) / (97 + 40) \times 525 \\ &= 484 \text{ k} \end{aligned}$$

b. Wind

The maximum wind moment in the chords occurs in the Vierendeel panel.

$$M = 86.87 \text{ ft-k (from Section 3.4 for typical truss T1B)}$$

$$\phi_{ecc} \times M = 1.89 \times 86.87 = 164 \text{ ft-k}$$

$$M_u = \boxed{164 \times 1.3} = 213 \text{ ft-k}$$

The axial force applied to the chord due to the wind load can be neglected as will be explained in Section 3.8. The above moment is also applied to the adjacent span, which has a span length of 9.5 ft same as the span length used for the gravity load moment calculation. The member forces of the chords on the second story due to gravity and wind loads are then combined as follows:

$$P_u = 484 \text{ k}$$

$$M_u = 41 + 213 = 254 \text{ ft-k}$$

It is observed that while wind loads vary with building heights, gravity loads do not. Thus, Table 3.2 is created and the chord moments are calculated using coefficient ϕ_{cc} of each story as shown. The designed wide-flange sections per AISC Equation H1-1a are also shown in the table. To facilitate the design calculations, the axial force and bending moment strengths of possible W10 members are calculated first and listed in Table 3.3.

3.8 Computer Modeling

When designing staggered truss buildings using computer models (stiffness matrix solutions), the results vary with the assumptions made regarding the degree of composite action between the trusses and the concrete floor. The design results are particularly sensitive to modeling because a bare truss is more flexible than a truss modeled with a concrete floor. Upon grouting, the truss chords become composite with the concrete floor and thus the floor shares with the truss chords in load bearing. Yet, a concrete floor, particularly a concrete plank floor, may not effectively transmit tensile stresses. Also, there is limited information on plank and steel composite behavior. In addition, lateral loads are assumed to be distributed to the trusses by the concrete floor diaphragm and the participation of the truss chords in distributing these forces may be difficult to quantify.

A reasonable approach to this problem is the assumption that the diaphragm is present when solving for lateral loads, but is ignored when solving for gravity loads. This requires working with two computer models—one for gravity loads

Rev.
12/1/02

Rev.
5/1/03

Table 3.1 Design of Diagonal Member d1 of Truss T1F

DIAGONAL MEMBER d1, TRUSS T1F										
Floor	WIND, kips		SEISMIC, kips		LOAD COMBINATIONS, kips					Member Sizes
	Φ_h^d	$\Phi_{ecc}\Phi_h F_w$	Φ_h^d	$\Phi_{ecc}\Phi_h F_E$	(1)	(2)	(3)	(4)	(5)	
Roof	9%	12	13%	10	377	412^a	366	361	DOFS NOT GOVERN	HSS 10x6x1/2
12	18	24	26	20	377	412	382	370		HSS 10x6x1/2
11	27	36	39	29	377	412	397	380		HSS 10x6x1/2
10	36	48	51	38	377	412	413	389		HSS 10x6x1/2
9	45	60	61	46	377	412	428	397		HSS 10x6x1/2
8	54	72	70	53	377	412	444	404		HSS 10x6x1/2
7	62	82	78	59	377	412	458	410		HSS 10x6x1/2
6	70	93	85	64	377	412	471	415		HSS 10x6x1/2
5	78	103	91	69	377	412	485	419		HSS 10x6x1/2
4	86	114	95	72	377	412	499	422		HSS 10x6x1/2
3	93	123	98	74	377	412	511	425		HSS 10x6x1/2
2	100%	133	100	75	377	412	352	426	HSS 10x6x1/2	
Ground		133		75	377	412	523	426	HSS 10x6x1/2	
F in d1 of Typical Truss T1B		70.2 ^b		39.9 ^b	380 ^c					

DL = 97 psf, LL = 40 psf, RLL = 20 psf

$\Phi_w = 1.0$ (see Section 3.5)

$\Phi_{ecc} = 1.89$ (from Table 2.3)

Note:

a. $F_w = 70.2$ k (from Fig. 3.4)

b. $F_E = 70.2 \times 652 / 1,148 = 39.9$ k (refer to Table 1.2)

c. $F_G = 380$ k (refer to Fig. 3.3)

d. Φ_h values are from Table 1.2

e. Numbers in boldface indicate the load case governs

Φ_{L1} (for load combination 1.4D) = $1.4 \times 97 / (97 + 40) = 0.991$

Φ_{L2} (for load combination 1.2D + 1.6L) = $(1.2 \times 97 + 1.6 \times 20) / (97 + 40) = 1.083$

Φ_{L3} (for load combination 1.2D + 0.5L) = $(1.2 \times 97 + 0.5 \times 20) / (97 + 40) = 0.923$

Load combination (1): $1.4D = \Phi_{L1} F_G$

Load combination (2): $1.2D + 1.6L = \Phi_{L2} F_G$

Load combination (3): $1.2D + 1.3W + 0.5L = \Phi_{L3} F_G + 1.3 \Phi_{ecc} \Phi_h F_w$

Load combination (4): $1.2D + 1.0E + 0.5L = \Phi_{L3} F_G + \Phi_{ecc} F_E$

Load combination (5): $0.9D + (1.3W \text{ or } 1.0E)$

Table 3.2 Design of Staggered Truss Chords						
TRUSS T1F						
Floor	Φ_h	$M_{u,w}$	M_u	P_u	Section	AISC Eq. H1-1a
Roof	9%	19	60	484	W10×54	
12	18	38	79	484	W10×54	1.0
11	27	58	96	484	W10×60	
10	36	77	118	484	W10×60	1.0
9	45	96	137	484	W10×68	
8	54	115	151	484	W10×68	0.99
7	62	132	173	484	W10×77	
6	70	149	190	484	W10×77	
5	78	166	207	484	W10×77	1.0
4	86	183	224	484	W10×88	
3	93	198	239	484	W10×88	
2	100	213	254	484	W10×88	0.97
Ground						

$$M_u = M_{u,G} + M_{u,W}$$

$M_{u,G}$ = Gravity load moment = 41 ft-k every story

$M_{u,W}$ = Wind load moment.

Table 3.3 Section Strengths for Chord Design, $F_y = 50$ ksi		
Section	$\phi_c P_n$ (k)	$\phi_b M_{nx}$ (ft-k)
W10×112	1400	551
W10×100	1250	488
W10×88	1100	424
W10×77	961	366
W10×68	850	320
W10×60	748	280
W10×54	672	250
W10×49	612	226
W10×45	565	206
W10×39	489	176
W10×33	413	146

and the other for lateral loads, and then the results are combined using load factors per code requirements. In combining the results, it is assumed that any axial load actions from lateral loads are carried only in the concrete floor, but out-of-diaphragm-plane shear and moment actions from lateral loads are resisted by the steel chords.

3.9 Columns

The floor loads are delivered to the columns through the truss-to-column connections. For trusses, the first diagonal is responsible for carrying most of this load into the connection. Thus, for a typical one-story truss, the first diagonal-to-column connection will carry the accumulated load

from two floors. For a truss with hangers or posts (Truss type T2), the first diagonal-to-column connection will carry the accumulated load from three floors.

A difficulty exists in evaluating the actions imposed on the columns by the truss flexibility. The column design is best done using the shear and moment applied to the columns obtained from construction loads (plate loads) on a bare truss. Column forces due to superimposed dead and live loads and lateral loads are computed from a composite truss.

Since columns support large tributary areas, the maximum live load reduction is permitted. For the purpose of this example, 50% reduction is assumed. The load combi-

nation of gravity loads, either 1.4D or 1.2D + 1.6L, governs the column designs. The following shows the design of column 1F. Refer to Fig. 1.4 for the column location and Section 1.3 for the dead and live loads used in the calculations.

Column Axial Force

$$\begin{aligned} \text{Tributary Area} &= 72 / 2 \times 64 / 2 = 1,152 \\ \text{DL}_1 \text{ (plate loads only)} &= 80 \text{ psf} \times 1,152 = 92.2 \text{ k} \\ \text{DL}_2 \text{ (all dead loads except exterior walls)} \\ &= 97 \text{ psf} \times 1,152 = 111.7 \text{ k} \\ \text{RLL} &= 20 \text{ psf} \times 1,152 = 23 \text{ k} \\ \text{DL}_2 + \text{RLL} &= 111.7 + 23 = 134.7 \text{ k} \end{aligned}$$

Two Floors:

$$\begin{aligned} \text{DL}_1 &= 92.2 \times 2 = 184 \text{ k} \\ \text{DL}_2 + \text{RLL} &= 134.7 \times 2 = 269 \text{ k} \\ \text{Exterior wall: } &48 \text{ psf} \times 36' \times 9' = 16 \text{ k per story} \end{aligned}$$

Column Bending

The truss axial deformation and downward deflection due to gravity loads force the column-to-truss joints to translate and rotate. It is assumed that the truss moment of inertia is much larger than the columns. The assumed deformed shape of the columns due to joint rotation is shown in Fig. 3.7(b). The member end moment caused by a unit rotation is calculated as $3EI/\ell_c$ for this deformed shape. The member end moment caused by a unit translation is $6EI/\ell_c^2$ as indicated in Fig. 3.7(a). The moment of the column due to gravity load is thus calculated as follows:

$$\begin{aligned} M_{\text{COL}} &= M_{\text{TRANS}} + M_{\text{ROT}} \\ M_{\text{TRANS}} &= 6EI (\Delta_t + \Delta_b) / \ell_c^2 \\ M_{\text{ROT}} &= -3EI\theta / \ell_c \end{aligned}$$

where

$$\theta = 2\Delta_{\text{TS}} / L$$

$$\therefore M_{\text{COL}} = \frac{6EI}{\ell_c} \left(\frac{\Delta_t + \Delta_b}{\ell_c} - \frac{\Delta_{\text{TS}}}{L} \right)$$

where

$$\begin{aligned} \Delta_t &= \text{Top chord axial deformation} \\ &= \Sigma P_i L_i / EA_i \\ \Delta_b &= \text{Bottom chord axial deformation} \\ &= \Sigma P_i L_i / (EA_i) \\ \Delta_{\text{TS}} &= \text{Truss midspan deflection} \\ L &= \text{Truss span} \\ \ell_c &= \text{Column length} \end{aligned}$$

Example:

Only the dead loads of planks and structural steel are used to calculate column moments. Superimposed dead and live loads are applied after the erected planks act integrally with the steel trusses. Additional column moments due to superimposed dead and live loads can be neglected because the truss deformation caused by the superimposed loads is very small as a result of the composite action of the truss and the planks. However, these superimposed loads will increase the column axial force.

$$\Delta_{\text{TS}} = \frac{3}{4} \text{ in. (assumed truss midspan deflection due to weights of planks and structural steel)}$$

$$L = 64'$$

$$\ell_c = 9'$$

For the top and bottom chords of W10×54:

$$\begin{aligned} \Delta_t &= \Sigma P_i L_i / (EA_i) \\ &= [(9.5 \times 12) / (29,000 \times 15.8)] \\ &\quad \times (268.6 + 443.6 + 525 + 525/2) \\ &\quad \times [80/(97 + 40)] \\ &= 0.218 \text{ in.} \end{aligned}$$

$$\begin{aligned} \Delta_b &= [(9.5 \times 12) / (29,000 \times 15.8)] \\ &\quad \times (0 + 268.6 + 443.6 + 525/2) \\ &\quad \times [80/(97 + 40)] \\ &= 0.142 \text{ in.} \end{aligned}$$

The chord axial forces used in the above calculations are from Fig. 3.3. Try W12×65 for the column section.

$$\begin{aligned} M &= [6 \times 29000 \times 174 / (9 \times 12)] \\ &\quad \times [(0.218 + 0.142) / (9 \times 12)] \\ &\quad - 0.75 / (64 \times 12)] \\ &= 661 \text{ in-k} \\ &= 55 \text{ ft-k} \end{aligned}$$

where moment of inertia I_y (rather than I_x) is used because the columns bend about the weak axis. The column moment calculated above is for the top story. For other stories, the moments can be calculated similarly and the results are shown in Table 3.4. It is noted that axial deformations D_t and D_b are less in the bottom stories because of bigger chord member sections. However, the column moments are larger in the bottom stories because the column moment of inertias, I_y , are bigger in the bottom stories. These column moments are then combined with the axial forces using load factors for different load combinations. The results of the load combinations and the column sections selected based on the most severe load case are shown in Table 3.4. Column axial loads due to lateral loads, in this example, are small and therefore, left out.

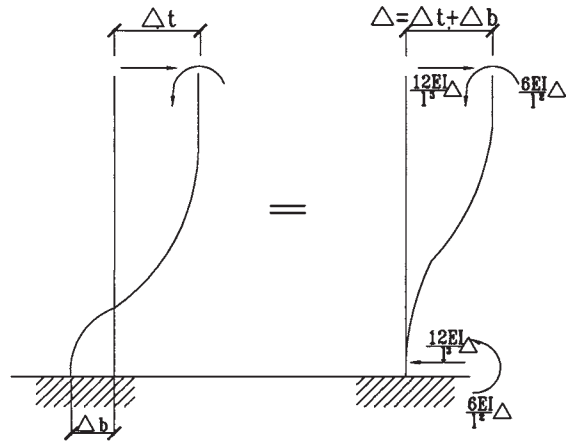

(a) TRANSLATION

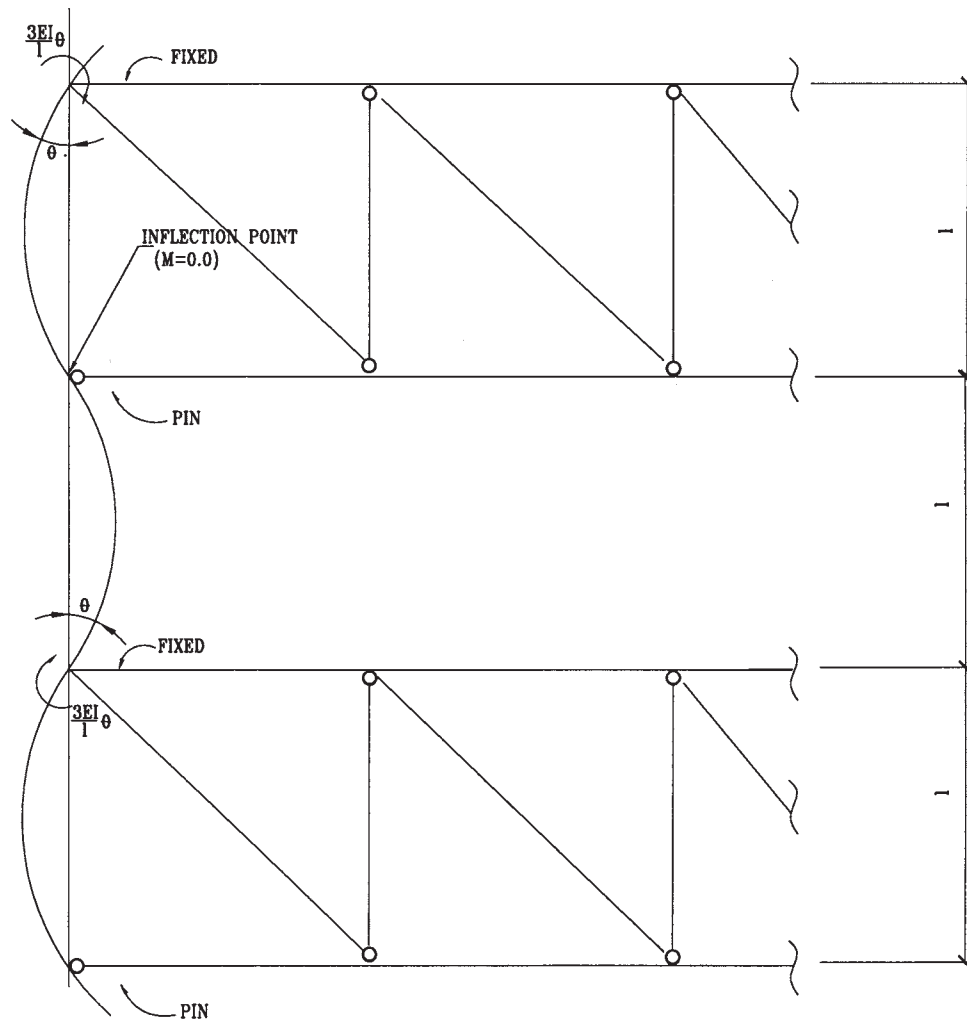

(b) ROTATION

Fig. 3.7 Column deformed shaped due to chord displacement.

Table 3.4 Design of Column 1F												
COLUMN 1F												
	Axial Force						Moment	Load Combinations				Section
	Floor		Exterior Wall (3)	Total		1.4 D		1.2 D + 1.6 L				
	DL ₁ (1)	DL ₂ + RLL (2)		DL ₁ (4)	DL ₂ + RLL (5)	Exterior Wall (6)		P _u (8)	M _u (9)	P _u (10)	M _u (11)	
Roof	184	269	16	184	269	16	55	258	77	360	66	W12×65
12			16	184	269	32		258		380		W12×65
11	184	269	16	368	538	48	65	515	91	740	78	W12×87
10			16	368	538	64		515		759		W12×87
9	184	269	16	552	807	80	77	773	108	1120	92	W12×120
8			16	552	807	96		773		1139		W12×120
7	184	269	16	736	1076	112	82	1030	115	1499	98	W12×152
6			16	736	1076	128		1030		1518		W12×152
5	184	269	16	920	1345	144	97	1288	136	1879	116	W12×190
4			16	920	1345	160		1288		1898		W12×190
3	184	269	16	1104	1614	176	105	1546	147	2258	126	W12×230
2			16	1104	1614	192		1546		2278		W12×230
Ground	184 k	269 k	16 k	1288 k	1883 k	208 k	55 ft-k					

Note: 1. DL₁ includes the weights of precast planks and structural steel only.

2. DL₂ includes all the dead loads except the weight of exterior walls.

3. All the columns bend about the weak axis (see Fig. 1.4).

4. The moments shown in the table are caused by the weights of precast plank and structural steel only.

5. Column (8) = 1.4 × Column (4); Column (9) = 1.4 × Column (7).

6. Column (10) = (1.2 × 97 + 1.6 × 20) / (97 + 20) × Column (5) + 1.2 × Column (6); Column (11) = 1.2 × Column (7).

Chapter 4

CONNECTIONS IN STAGGERED TRUSSES

4.1 General Information

The typical connection of web members to truss chords consists of welded gusset plates. Since the truss is shop fabricated and transported in one piece, all connections are shop welded (see Fig. 4.1). Only truss-to-column connections are bolted in the field (Fig. 4.2) when the truss is erected.

The HSS web member connection to the gusset plate is often made by cutting a slot in the middle of the HSS section. The design methodology that follows is based upon the recommendations listed in the *AISC Hollow Structural Sections Connections Manual* (AISC, 1997). Shown in Fig. 4.1 is a typical slotted HSS to gusset plate connection. Seismic behavior and design of gusset plates was studied by Astaneh-Asl (1998), and will be discussed in Chapter 5.

4.2 Connection Between Web Member and Gusset Plate

First, consider an HSS web member in tension. The design strength of the connection between the HSS and the gusset plate is the smallest value among the following four limit state considerations.

1. Shear Lag Fracture Strength in the HSS

$$\phi R_n = \phi F_u A_e$$

$$\phi = 0.75$$

2. Shear Strength of the HSS at Welds

$$\phi R_n = \phi V_n = \phi (0.6 F_y)(4L_w t)$$

$$\phi = 0.9$$

3. Strength of the Weld Connecting the Gusset Plate to the HSS

$$\phi R_n = \phi F_w A_w$$

$$\phi = 0.75$$

4. Shear Strength of the Gusset Plate

$$\phi R_n = \phi V_n = \phi (0.6 F_{y1})(2L_w t_1)$$

$$\phi = 0.9$$

The notations used in the above four limit state strength expressions are as follows:

- F_u = specified minimum tensile strength of the HSS, ksi
- F_y = specified minimum yield stress of the HSS, ksi
- A_e = effective net area of the HSS, in²
= $U A_n$
- A_n = $A_g - 2 t t_1$
- A_g = gross area of the HSS, in²

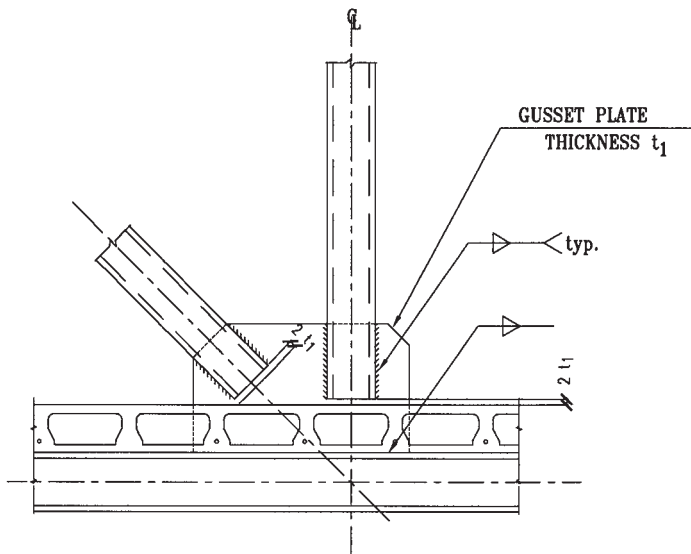

Fig. 4.1 Slotted HSS and gusset plate connection.

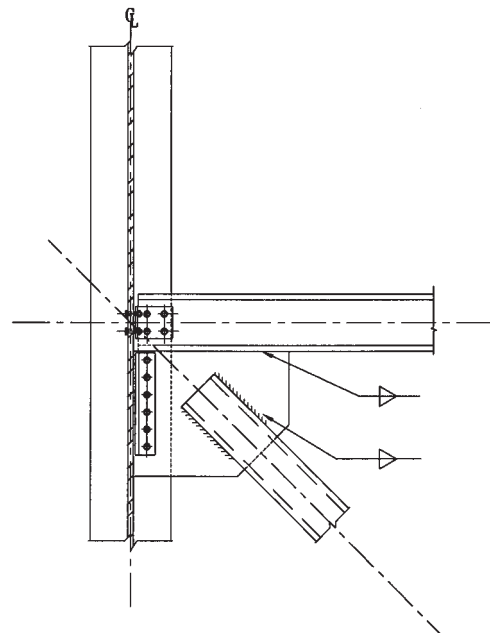

Fig. 4.2 Truss to column connection.

$$U = 1 - (x / L_w) \leq 0.9$$

$$x = \bar{x} = \frac{B^2 + 2BH}{4(B + H)} \text{ for rectangular HSS}$$

L_w = length of the weld to HSS, in
 $\geq 1.0 H$ (As a rule of thumb, L_w should not be less than the HSS depth)

$4L_w$ = total weld length

B = width of the HSS section, in

H = depth of HSS section, in

t = HSS wall thickness, in

t_1 = gusset plate thickness, in

F_w = nominal weld strength, ksi
 $= 0.60 F_{EXX} (1.0 + 0.5 \sin^{1.5} \theta)$

F_{EXX} = electrode classification number, i.e., minimum specified strength, ksi

θ = angle of loading measured from the weld longitudinal axis

A_w = effective area of weld throat, in²
 $= 0.707 W_e (4 L_w)$

W_e = effective weld size, in
 $= W_w - 1/16"$

W_w = weld size, in

F_{y1} = specified minimum yield stress of the gusset plate, ksi

In case the HSS web member is in compression, in addition to the limit states (2), (3), and (4) stated above, the following limit state has to be considered as well.

5. Strength Based on Buckling of the Gusset Plate

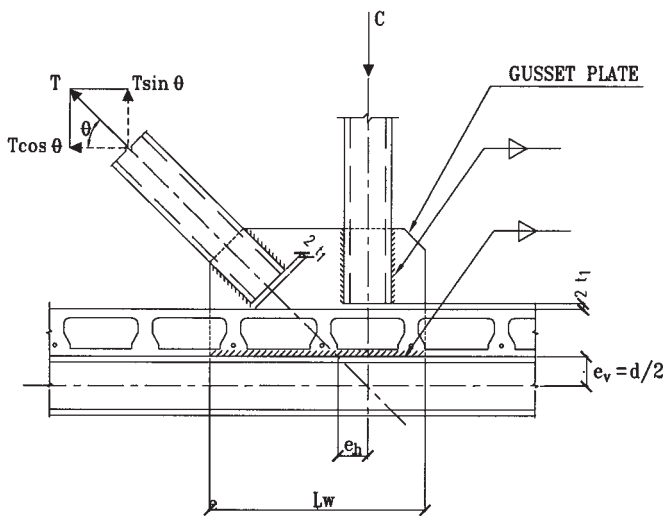

Fig. 4.3 Forces to be considered at the weld connecting gusset plate and chord.

The provided compression strength is calculated based on simple column buckling procedures. The procedure assumes that both ends of the gusset plate are fixed and can sway laterally (See Fig. 4.3 and 4.4).

$$\phi_c P_n = \phi_c A_g F_{cr}$$

where

$\phi_c = 0.85$

P_n = nominal compressive strength, kips

A_g = gross area of gusset plate, in². Whitmore's 30-degree effective width area (Whitmore, 1952; Astaneh-Asl, Goel, and Hanson, 1981) should be used for a large gusset plate.

F_{cr} = critical compressive stress, ksi

$$= 0.658^{\lambda_c^2} F_{y1} \text{ for } \lambda_c \leq 1.5$$

$$= (0.877 / \lambda_c^2) F_{y1} \text{ for } \lambda_c > 1.5$$

λ_c = slenderness parameter

$$= \frac{k \ell}{r \pi} \sqrt{\frac{F_{y1}}{E}}$$

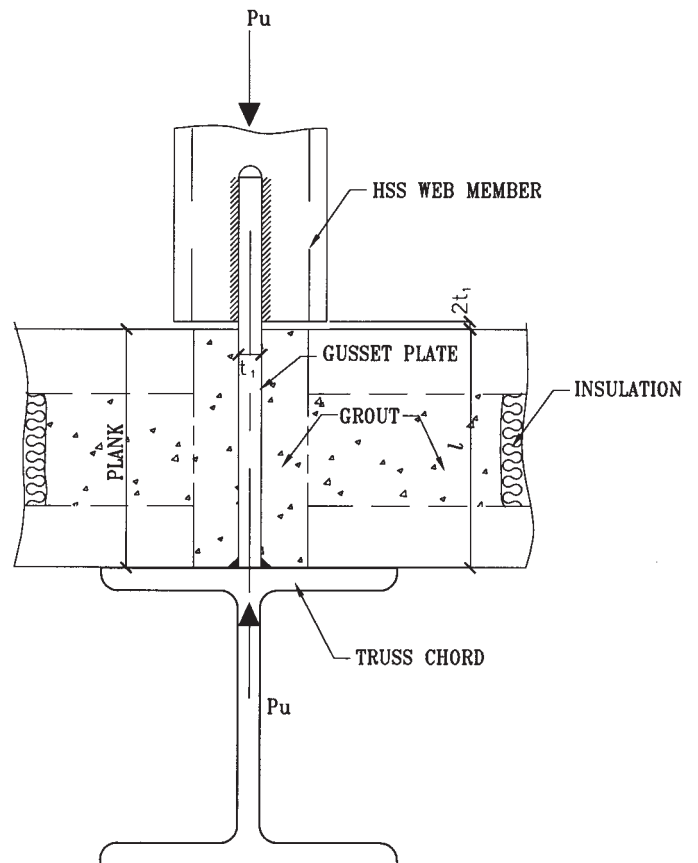

Fig. 4.4 Gusset plate in compression.

- F_{y1} = specified minimum yield stress of the gusset plate, ksi
 E = modulus of elasticity, ksi
 k = effective length factor = 1.2
 ℓ = laterally unbraced length of plates, in
 r = governing radius of gyration, in
 $= t_1 / \sqrt{12}$
 t_1 = gusset plate thickness, in

4.3 Connection Between Gusset Plate and Chord

The stress distribution in the weld connecting the gusset plate and the chord is much more complex. As shown in Fig. 4.3, the weld is subject to shear force $V = T \cos \theta$, tensile force $P = T \sin \theta - C$, and moment

$$\begin{aligned}
 M &= T \cos \theta \times e_v - P \times e_h \\
 &= T \cos \theta \times d / 2 - (T \sin \theta - C) \times e_h
 \end{aligned}$$

If no vertical external load is applied at the joint, tensile force $P = T \sin \theta - C$ is zero. While shear force V causes shear stress in the weld, tensile force P and moment M induce tensile or compressive normal stress. These stresses must be combined vectorially. In design, a unit throat thickness of the weld is usually assumed in the stress calculations. The maximum stress caused by the combination of factored V , P , and M must be equal to or less than the strength of the weld. The provided design strength of a unit length of weld is

$$\phi R_n = \phi F_w A_w = \phi(0.6 F_{EXX})(0.707 W_w)$$

where $\phi = 0.75$. Meanwhile, the maximum shear stress caused by the direct shear must be less than the shear strength of the gusset plate. The provided design shear strength of the gusset plate per unit length along the weld connection is given by

$$\phi R_n = \phi V_n = \phi(0.6 F_{y1}) t_1$$

where $\phi = 0.9$

4.4 Design Example

The connection design of diagonal member d1 in Truss T1F to the chord of the second story is calculated in this example.

Diagonal member d1: HSS $10 \times 6 \times \frac{1}{2}$

$P_u = 523$ k (in tension, see Table 3.1)

Connection between the HSS and the gusset plate:

1. Shear Lag Fracture Strength in the HSS

$$\begin{aligned}
 \phi R_n &= \phi F_u A_e \\
 A_n &= A_g - 2 t t_1 = 13.5 - 2 \times 0.465 \times \frac{1}{2} \\
 &= 13.04 \text{ in}^2 \\
 L_w &= 20 \text{ in} \\
 \bar{x} &= (6 + 2 \times 6 \times 10) / 4 (6 + 10) \\
 &= 2.44 \text{ in} \\
 U &= 1 - 2.44 / 20 = 0.88 < 0.9 \\
 \phi R_n &= 0.75 \times 62 \times 0.88 \times 13.04 \\
 &= 534 \text{ k}
 \end{aligned}$$

2. Shear Strength of the HSS at Welds

$$\begin{aligned}
 \phi R_n &= \phi (0.6 F_y)(4 L_w t) \\
 &= 0.9 \times 0.6 \times 46 \times 4 \times 20 \times 0.465 \\
 &= 924 \text{ k}
 \end{aligned}$$

3. Strength of the Weld Connecting the Gusset Plate to the HSS

$$\begin{aligned}
 \phi R_n &= \phi F_w A_w \\
 \theta &= 0^\circ \text{ (the load direction is parallel to the weld direction)} \\
 F_{EXX} &= 70 \text{ ksi} \\
 F_w &= 0.6 \times 70 \times (1.0 + 0) = 42 \text{ ksi} \\
 A_w &= 0.707 \times (3/8 - 1/16) 4 \times 20 \\
 &= 17.68 \text{ in}^2 \\
 \phi R_n &= 0.75 \times 42 \times 17.68 \\
 &= 557 \text{ k}
 \end{aligned}$$

4. Shear Strength of the Gusset Plate

$$\begin{aligned}
 \phi R_n &= \phi(0.6 F_{y1})(2 L_w t_1) \\
 &= 0.9 \times 0.6 \times 50 \times 2 \times 20 \times \frac{1}{2} \\
 &= 540 \text{ k}
 \end{aligned}$$

The smallest value among the four cases above governs, i.e., $\phi R_n = 534$ k, which is larger than $P_u = 523$ k.

Calculations also must be made for the connection between the gusset plate and the chord to ensure its strength is adequate.

4.5 Miscellaneous Considerations

Reinforcement of trusses can be accomplished using field welded plates and channels (see Figs. 4.5 and 4.6). It is advised to leave the chord web free of stiffeners, plates, etc., so as to allow future sistering of channels to be fitted in the web.

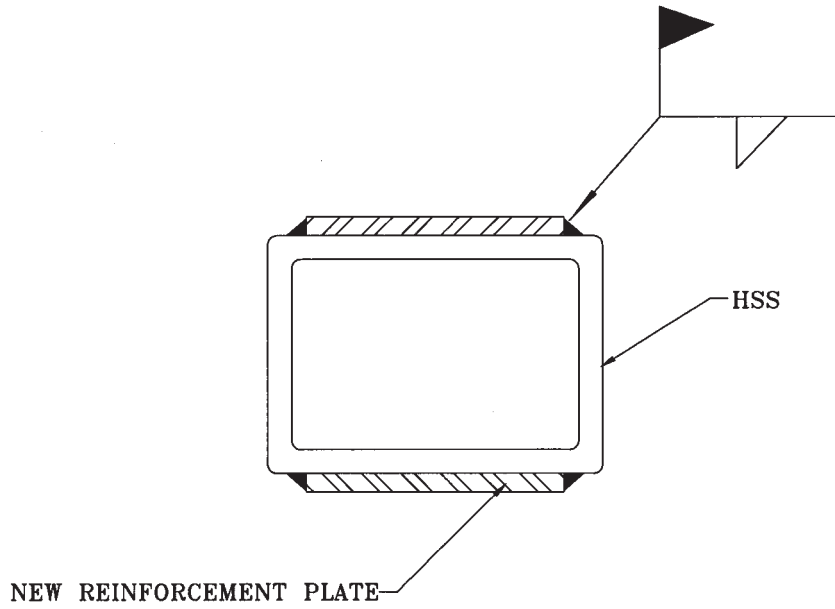

Fig. 4.5 Truss HSS reinforcement detail.

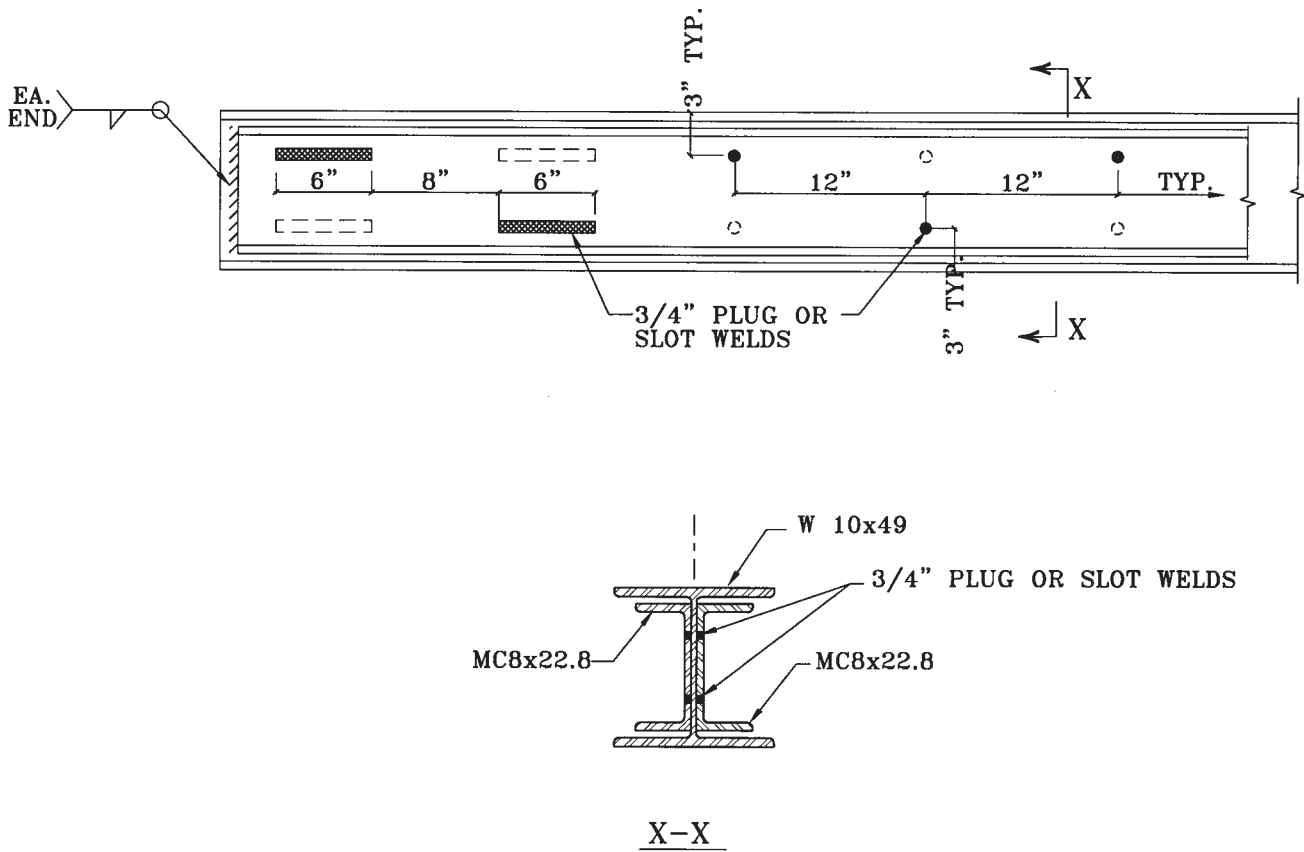

Fig. 4.6 Truss chord reinforcement detail.

Chapter 5

SEISMIC DESIGN

5.1 Strength and Ductility Design Requirements

The staggered truss system provides excellent lateral resistance in the transverse direction of the building (the direction of the trusses). A separate lateral-force-resisting system must be provided in the longitudinal direction of the building. This longitudinal lateral-force-resisting system usually consists of perimeter moment frames on the exterior of the building or bracing systems organized around the building elevator cores and stair towers.

In designing a staggered-truss system for seismic forces, several questions related to the system behavior must be addressed. Of primary importance is the selection of an appropriate seismic response modification factor R to be used in developing the base shear of the building in the staggered truss direction. Prior research both in the United States and Japan has indicated that the staggered-truss system behaves as a combination of a braced system and a ductile moment resisting system under the action of seismic excitation. Hanson and Berg (1973) have shown that with proper detailing, the Vierendeel panel in the center of the truss can provide significant ductility in the structural response. The presence of braces in the other panels concentrates the energy dissipation to the Vierendeel panel. In order to ensure that this is the primary source of energy dissipation, the bracing diagonals and their connections should be designed to remain nominally elastic under the assumed seismic forces. Equal care must be taken in the design of the diaphragm system, which is an integral part of the resisting system to transfer lateral forces. It is essential to design the diaphragm to keep the in-plane stresses below yield limits.

In regions of high-seismic activity (that is, when it is desirable or required to provide a system with an R factor greater than 3), researchers suggest that the behavior of the staggered-truss system be evaluated utilizing time history analysis enveloped with a spectrum for the site under consideration. The ductility demands on the chords can then be evaluated directly from the analysis. The response characteristics of a staggered-truss structure that dissipates energy mainly through Vierendeel panels are similar to a ductile moment frame or an eccentrically braced frame. This would imply that an R factor of 7 or 8 could be used for the design in the transverse direction of the building.

In regions of moderate seismic activity, using a response modification factor equivalent to that used for ordinary moment frames ($R = 4.5$) would be appropriate (Hanson and Berg, 1973). However, given the limited data available, the designer may select a more conservative value of $R = 3$ for the overall behavior. When R is taken as 3, special seis-

mic detailing is not required. In selecting an appropriate natural period of the building to be used in calculating the base shear, it is recommended that the classification of the structure type be assigned on the basis of the way the seismic energy is dissipated. The presence of the braces in the truss system does not influence the ductility of the system since these elements and their connections are designed to avoid yielding under a seismic event.

5.2 New Seismic Design Provisions for Precast Concrete Diaphragms

According to Ghosh (1999) and Hawkins and Ghosh (2000), the Uniform Building Code has required that in regions of high seismicity (zones 3 and 4—i.e., when R is taken greater than 3) cast-in-place topping slabs over precast planks must be designed to act as the diaphragm, without relying on the precast elements. The design philosophy is that a topping slab acts in the same manner as a cast-in-place reinforced concrete slab under in-plane lateral loads. The Northridge earthquake showed that this is not the case. In some cases the topping cracked along the edges of the precast elements and the welded wire fabric fractured. Accordingly, the diaphragms may have become the equivalent of untopped diaphragms with the connections between the planks, the chords, and the collectors not detailed for that condition.

Unlike topped diaphragms, untopped hollow-core plank diaphragms with grouted joints and chords have performed satisfactorily in earthquakes and in laboratory tests. Thus, according to Ghosh (2000), when diaphragms are designed using appropriate forces to ensure continuity of load path, force development across joints, deformation compatibility, and connections of adequate strength, they may perform well even untopped.

5.3 Ductility of Truss Members

Staggered trusses normally use rectangular HSS, which act mostly as concentrically braced frames (CBF). CBF's are characterized by a high elastic stiffness, which is accomplished by the diagonal braces that resist lateral forces by developing internal axial actions. Only the chords, which span across Vierendeel panels at corridors and openings provide some flexibility and energy dissipation capacity by developing out-of-plane flexural and shear actions.

For braced frames, tension-only systems are not considered to provide a sufficient level of energy dissipation capability. They are assigned a small response modification

factor R , and are designed for larger forces than the nominal design force to account for impact. Compression braces, however, are susceptible to fracture failure induced by local buckling and subsequent material failure, unless stringent seismic slenderness ratios are provided. Local buckling in HSS reduces the plastic moment resistance and consequently the axial compressive strength. Furthermore, the degree and extent of the local buckling at the plastic hinge has a major influence on the fracture life of the brace. Preventing severe local buckling is the key to precluding premature material fracture. The onset of local buckling can be delayed until significantly into the inelastic range by reducing the width-to-thickness ratio b/t of the brace. In high-seismic applications, from the AISC Seismic Provisions, the b/t ratio for HSS should be limited to $110\sqrt{F_y}$.

The exact contribution of Vierendeel panels to energy dissipation in staggered trusses has not been documented. Subsequently, new resources for research on this topic are necessary.

Black (1980) suggested that the most efficient braces are tubular cross-sections with small kl/r . He also suggested that improved performance can be achieved by reducing the b/t ratios of the rectangular brace HSS. Black ranked the tested cross-sections in the following descending order of effectiveness for a given slenderness ratio:

1. Round HSS brace
2. Rectangular HSS brace
3. I-shaped brace
4. T-shaped brace
5. Double-angle brace

Black recommended that built-up members not be used as braces for applications in which severe cyclic loading is anticipated unless the members making up the built-up section were adequately stitched together.

5.4 Seismic Design of Gusset Plates

During an earthquake excitation, the gusset plates connecting bracing members should have sufficient ductility to deform and provide the end rotation demands of the members. To avoid brittle behavior of the structure, the gusset plate connections should be governed by a yielding failure mode rather than a fracture mode. This can be achieved by designing the failure modes in a hierarchical order in which the ductile failure modes such as yielding occur prior to the brittle failure modes such as fracture.

Bracing members and sometimes gusset plates are the most active elements during an earthquake. Four zones can be identified in a bracing system: bracing member, connection of the bracing member to the gusset plate, gusset plate, and connection of the gusset plate to the chord. Each of the above four zones has its own failure modes, and the gov-

erning failure mode within each of the zones should be ductile. In order to increase the global ductility of the braced frame, the occurrence of the yielding in the four zones should be in the following order: yielding of bracing member, yielding of gusset plate, and yielding of connection elements such as welds. Yielding of bracing member results in large axial plastic deformations, which in turn results in large ductility of the braced frame. On the other hand, yielding of relatively short welds cannot provide large global ductility.

The emphasis of this section is on the seismic design of gusset plates. Failure modes of a typical gusset plate in the order of ductility desirability are as follows (Astaneh-Asl, 1998):

1. Yielding of Whitmore's area of gusset plate

This is most desirable failure mode of a gusset plate. Yielding caused by direct tension or compression can occur in the Whitmore effective width area (Whitmore, 1952; Astaneh-Asl, Goel, and Hanson, 1982). The yield strength of the failure mode is

$$P_y = A_{gw}F_y$$

where A_{gw} = gross area of gusset plate as per Whitmore's 30-degree lines and F_y = specified minimum yield stress of the gusset plate.

2. Yielding of critical sections of gusset plate under combined stresses

Critical sections of gusset plates can yield under a combination of axial load, bending, and shear. To determine strength of gusset plate subject to combined loads, the following interaction equation is suggested:

$$\left(\frac{N}{\phi N_y}\right)^2 + \frac{M}{\phi M_p} + \left(\frac{V}{\phi V_y}\right) \leq 1.0$$

where N , M , and V are the axial force, bending moment, and shear force on the critical section; ϕN_y , ϕM_p , and ϕV_y are the axial load strength in yielding, plastic moment strength, and strength in shear yielding, respectively.

3. Buckling of gusset plate

Whitmore's effective width area can be used to establish buckling strength of a gusset plate subject to direct compression:

$$P_y = A_{gw}F_y$$

where F_{cr} is the critical stress acting on a 1-in.-wide strip within the Whitmore effective width. The effective length factor K is suggested to be taken as 1.2 because of a possibility of end of bracing member moving out of plane.

4. Buckling of edges of gusset plate

A gusset plate may buckle along its free edge as shown in Fig. 5.1. The edge buckling limits the cyclic ductility of the gusset plate. To prevent edge buckling under severe cyclic loading, the following equation is proposed by Astaneh-Asl (1998):

$$\frac{L_{fg}}{t_1} \leq 0.75 \sqrt{\frac{E}{F_y}}$$

where L_{fg} , t_1 , and E are free edge length, thickness, and modulus of elasticity of the gusset plate, respectively.

5. Block shear failure

Block shear failure is a relatively less ductile failure mode and undesirable. To ensure that the strength of gusset plate in block shear failure is greater than its strength in yielding, the following criterion is suggested:

$$\phi_n P_{bs} \geq \phi(1.1R_y P_y)$$

where R_y is the ratio of expected yield strength to specified yield strength. The values of R_y are given in AISC Seismic Provisions for Structural Steel Buildings (1997). P_{bs} is the nominal strength of gusset plate in block shear failure, which can be calculated using the equations:

$$P_{bs} = 0.6R_y F_y A_{gv} + F_u A_{nt} \text{ for } F_u A_{nt} \geq 0.6F_u A_{nv}$$

$$P_{bs} = 0.6F_u A_{nv} + R_y F_y A_{gt} \text{ for } F_u A_{nt} < 0.6F_u A_{nv}$$

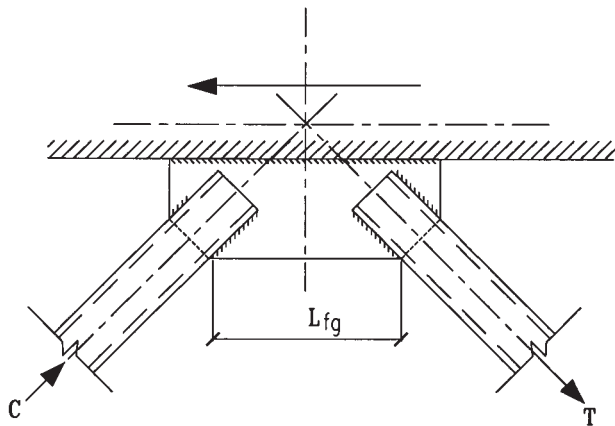

Fig. 5.1 Edge buckling of gusset plate.

where A_{gv} and A_{nv} are the gross and net areas subject to shear, and A_{gt} and A_{nt} are the gross and net areas subject to tension, respectively. F_u is the specified minimum tensile strength.

6. Fracture of net area of gusset plate

To ensure that this relatively brittle failure mode does not occur prior to yielding of gusset plate, the following criterion is suggested:

$$\phi_n P_n \geq \phi(1.1R_y P_y)$$

where $P_n = A_{nw} F_u$. A_{nw} is the net area of gusset plate along the Whitmore section.

5.5 New Developments in Gusset Plate to HSS Connections

Cheng and Kulak (2000) have determined on the basis of tests that the slotted end of the HSS is stiffened significantly as the result of the constraint provided by the gusset plate. In most of the physical tests, the geometries provided allowed yielding to occur in the gross section of the HSS without fracture in the net section of the connection region. However, use of a short weld length or the absence of transverse welds across the thickness of the gusset plate weld may increase the stress concentration sufficiently that fracture will take place where the HSS enters the gusset plate. In such a case, ductility will be reduced. Nevertheless, in all the configurations investigated by them, the slotted HSS exhibited considerable ductility, regardless of the location of fracture.

Based on tests and numerical analysis performed by them, it was concluded that shear lag does not significantly affect the ultimate strength of slotted tubular sections that are welded to gusset plates. The shear lag expression given in Section 2.1(b) of the AISC *Specification for the Design of Steel Hollow Structural Sections* underestimates the strength of a slotted tube-to-gusset plate connection. Nevertheless, a transverse weld can be used across the thickness of the gusset plate since it increases the ductility of the slotted member significantly without incurring much extra cost.

See Cheng and Kulak (2000) for further information.

Chapter 6

SPECIAL TOPICS

6.1 Openings

Where openings in the truss are needed for room access, Vierendeel panels can be designed in the truss geometry (Fig. 6.1). The effect of such a panel is one of shear transfer across the opening through bending in the chords, which increases the flexibility of the truss and the bending moments in the chords to both vertical and lateral loads. Larger members and rigid connections, at a premium, reduce this flexibility, but do not eliminate it. The problem can be solved by approximate methods or by using a computer program. The latter method is recommended for all special framing conditions. Connections for members framing a Vierendeel panel are shown in Figs. 6.1 and 6.2.

6.2 Mechanical Design Considerations

Vertical chases are needed for distribution of plumbing pipes and ducts. When needed, they should be sized and located to eliminate the need for stagger. Staggering results in a cost increase. The common solution is to increase the chase size and to locate it midway between the truss modules.

6.3 Plank Leveling

Precast plank is delivered to the site with camber. Fabrication variances may result in adjacent planks having differential camber.

Differential plank camber is best removed mechanically prior to grouting. This is accomplished by inserting threaded rods with lock plates and nuts in the joints and then forcing the planks together mechanically by turning the nuts. Grouting takes place after the planks are aligned.

Another way to create level floors is by using a leveling compound such as gypcrete.

6.4 Erection Considerations

Staggered trusses are fabricated in the shop and delivered to the site, generally in one piece. Erecting staggered trusses in busy downtown areas (such as New York City) does not present a special challenge. The usual steel tolerances, which are listed in the AISC *Code of Standard Practice*, are normally adequate for erection purposes, even for busy downtown locations.

For practical reasons, staggered truss buildings are at least six stories in height and generally at most 25 stories in height. Higher buildings are possible when the staggered trusses are supplemented with special wind and/or seismic frames and reinforced diaphragm floors. The reason for the height limit is the staked geometry at the roof and second floor, which is by necessity, discontinuous.

Economy is further achieved by lumping member sizes into a few groups. This will usually result in an increase in steel weight, but a reduced overall cost due to the associated savings in labor. Also, HSS sizes are used for vertical and diagonal members with those member properties listed in AISC *Hollow Structural Sections Connections Manual* (AISC, 1997).

Economy may also be achieved by using longer columns with fewer splices. Up to four stories tall columns have been used with no difficulty. The faster erection and reduced field labor more than compensates for the cost of the added material.

Structural stability is mandatory during erection. Temporary steel braces or tension cables are recommended. Plank

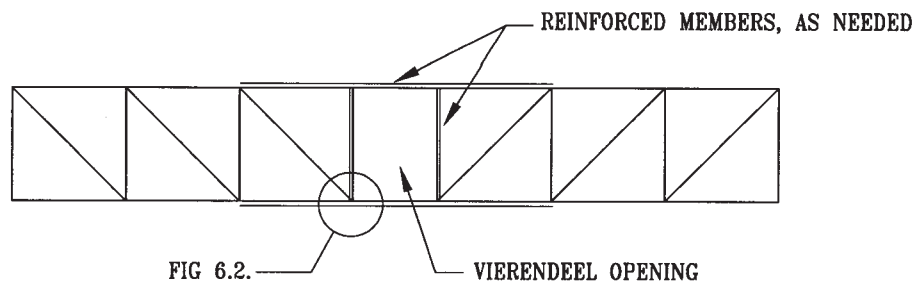

Fig. 6.1 Opening in truss using Vierendeel panel.

weld plates can also be used. The plank weight may provide bracing through friction at the interface with the truss chords. However, with friction alone, erection tolerances such as column plumbing may be jeopardized.

6.5 Coordination of Subcontractors

During construction, the steel and plank shop drawings may require special coordination. The plank manufacturer locates plank embedded items such as weld plates. The steel fabricator locates steel stiffeners, or wedges, shims, etc. A meeting between the steel and plank contractors is advis-

able to agree on dimensions. Such a meeting is best coordinated by the general contractor prior to the start of fabrication.

6.6 Foundation Overturning and Sliding

At foundation level, the codes require adequate safety factors against sliding and overturning. The safety factors vary with the building codes, but are usually 1.5. Sliding resistance is provided by friction of the footings and the basement slab against the soil, active pressure against the foundation walls, grade beams and footings, battered piles,

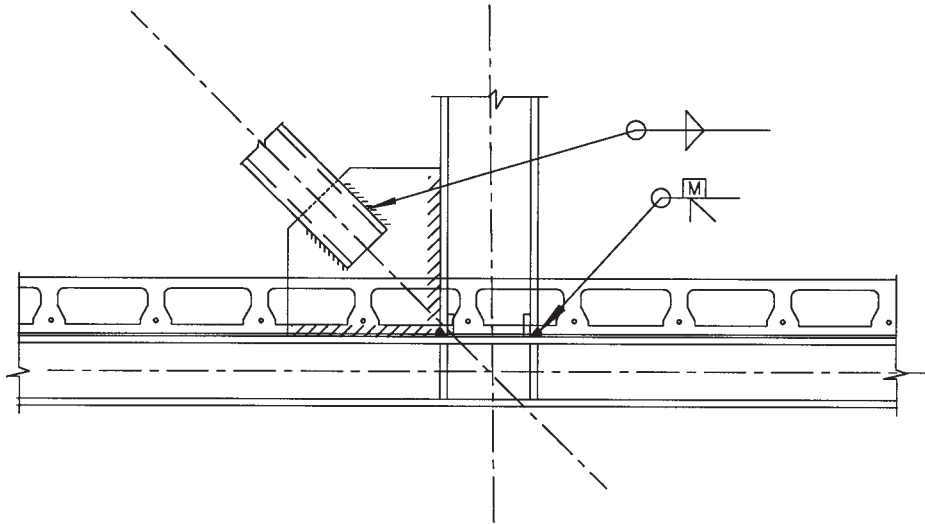

Fig. 6.2 Details at Vierendeel openings.

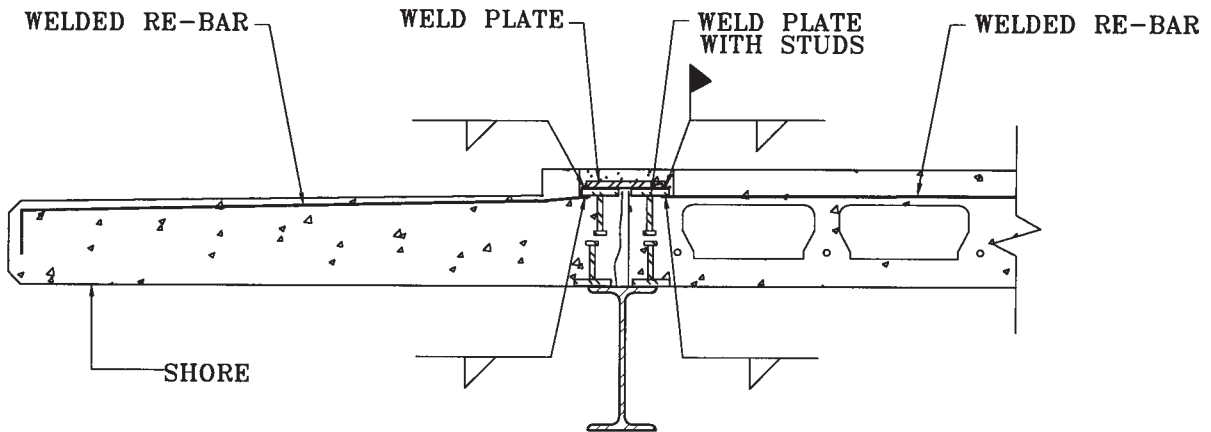

Fig. 6.3 Precast cantilever balcony.

etc. The engineer of record prepares calculations and provides the details required to ensure sliding and overturning safety.

Overturning with staggered trusses is usually not a concern for mid-rise buildings.

6.7 Special Conditions of Symmetry

The typical staggered truss is symmetrical about its centerline. Symmetry of geometry and symmetry of loads result in reduced member sizes. Non-symmetry results in increased sizes—most affected are the chords, which support out-of-plane actions. Such non-symmetry occurs at elevator machine rooms, at roof appurtenances, at public spaces on private floors and at large guest suites with access doors.

Pattern live loads often create non-symmetry. Pattern loadings are created by skipping the loads on alternate bays. With staggered trusses, if load patterns are created by skipping alternate bays, symmetry still remains. However, skipping loads in alternate rooms on the same side of the truss creates non-symmetry.

Future changes in truss geometry or loading is possible. Often, such modifications entail removal of diagonals and reinforcing of the chords. Chord reinforcement is accom-

plished with steel plates or with channels fitted within the web.

6.8 Balconies

Precast plank balconies are best manufactured using solid slabs. Since hollow cores entrap moisture, solid slabs are best used for durability. Fig. 6.3 shows a method of attachment of balconies.

6.9 Spandrel Beams

Spandrel beams support the exterior walls. Where precast concrete planks are perpendicular to spandrel beams, the spandrels support floor loads as well. The spandrel beams in the other direction support no floor loads. In addition, on the wide face of the building, the spandrels are an integral part of the moment frame for resisting wind and seismic loads. The design considerations for such frames are not within the scope of this design guide. The exterior wall is often eccentric with respect to spandrel beams and columns. A field weld between the plank and the beam flange strengthens the beam torsionally and enhances its ability to span between columns (see Fig. 2.6).

Chapter 7

FIRE PROTECTION OF STAGGERED TRUSSES

Fire safety is a fundamental requirement of building design and construction and fire resistance is one of the most vital elements of all components of a structure.

Qualifying criteria to meet these requirements are included in various building codes of national stature. These are used as standards in different areas of the country and which may or may not be further regulated by the local authorities having jurisdiction. The codes (and publishing organization) are:

- Standard Building Code (SBCCI)
- Uniform Building Code (ICBO)
- National Building Code (BOCA)

These code regulations are based on performance achieved through the standard ASTM E119 test (Alternative Test of Protection for Structural Steel Columns). Due to the dimensional constraints imposed by the fire testing chambers, specific fire tests for steel trusses that simulate actual conditions have not been performed. Therefore, individual truss members are regarded as columns for the purpose of rating their fire resistance and the applicable code requirement will be applied for each member.

By definition, a staggered truss spans from floor slab to floor slab. Slabs are typically pre-cast concrete and have a fire resistance rating. The truss and columns are other elements of this assembly requiring fire protection. There are basically two methods of providing fire protection for steel trusses in this type of assembly:

- Encapsulating it, in its entirety, with a fire-rated enclosure.
- Providing fire protection to each truss member.

In the former, enclosure can be any type of fire-rated assembly. Local regulation, however, might reference dif-

ferent testing laboratories as accepted standards for a particular fire rating.

For economy in materials and construction time, gypsum board and metal stud walls are preferred. Gypsum board type "X" and light-gage metal studs in any of the approved configurations for a particular rating is acceptable. However, removals of portions of the wall, renovations or additions with non-rated assemblies are issues that need to be considered to avoid possible future violations of fire rating integrity when choosing this method.

The other option is to protect each truss member with one of the following methods:

- If the truss is to be enclosed and/or protected against damage and without regard to aesthetics, gypsum-based, cementitious spray-applied fireproofing is often the most economical option.
- Intumescent paint films can be used where aesthetics are of prime concern, and visual exposure of the steel truss design is desired. In addition this product is suitable for interior and exterior applications. Nevertheless, this method is often one of the most expensive at the present time.
- For exterior applications and for areas exposed to traffic, abrasion and impact, a medium- or high-density cement-based formulation is suitable and can be trowel-finished for improved aesthetics.

Whatever method is chosen, the designer must work in close consultation with the product manufacturer by sharing the specifics of the project and relating the incoming technical information to the final design. Final approval must be obtained from the local authorities having jurisdiction over these regulations.

REFERENCES

- Astaneh-Asl, Abolhassan, *Seismic Behavior and Design of Gusset Plates*, Report of Department of Civil and Environmental Engineering, University of California, Berkeley, 1998.
- Astaneh-Asl, Abolhassan, Goel, S. C., and Hanson, R. D., *Cyclic Behavior of Double Angle Bracing Members with End Gusset Plates*, Report No. UMEE 82R7, University of Michigan, Ann Arbor, 1982.
- Berg, G. and Hansen, R.P., *A Seismic Design of Staggered Truss Buildings*, ASCE-1973.
- Brazil, Aine, P.E., “Staggered Truss System Proves Economical For Hotels”, *Modern Steel Construction* Report, September 2000, pp 34-39.
- Bruneau, Michael, Chia-Ming Uang and Whittaker, Andrew, *Ductile Design of Steel Structures*, New York, McGraw-Hill, 1998.
- Cheng, Roger and Kulak, Geoffrey L., “Gusset Plate Connection to Round HSS Tension Members”, *Engineering Journal*, AISC., Vol. 37, No. 4., December 2000, p.133.
- Cohen, P.M., “Design Solutions with Staggered Truss System”, *Modern Steel Construction* News, 1986, pp 5-12.
- Dudek, Paul H., *A Staggered Truss High-Rise Housing System*, New York: The Ronaid Press Company, 1960.
- Ghosh, S. K., “Changes Under Development in Seismic and Structural Code Provisions”, *PCI Journal*, V44, N6, November/December 1999, p. 96.
- Hawkins, Neil and Ghosh, S. K., “Proposed Revisions to 1997 NEHRP Recommended Provisions for Seismic Regulations for Precast Concrete Structures Part 3-Diaphragms”, *PCI Journal*, V45, N6, November/December 2000, pp. 50-58.
- Hibbeler, Russell, *Structural Analysis*, Prentice Hall, 1998.
- High-Rise Housing in Steel, the Staggered Truss System*, Massachusetts Institute of Technology, Departments of Architecture and Civil Engineering, January 1967.
- High-Rise Housing in Steel—The Staggered Truss System Research Report* (R67-7 Civil Engineering), Depts. of Architecture and Civil Engineering, Massachusetts Institute of Technology, Cambridge, Massachusetts, January, 1967.
- Hollow Structural Sections Connections Manual*, American Institute of Steel Construction, 1997.
- Hsieh, Yuan-Yu, *Elementary Theory of Structures*, Prentice Hall, 1998.
- Kirkham, William and Thomas H. Mille, “Examination of AISC LRFD Shear Lag Design Provisions”, *Engineering Journal*, AISC, Vol. 37, No. 3., November 2000, p. 83.
- Manual of Steel Construction, Load & Resistance Factor Design*, American Institute of Steel Construction, Vol.1, 2nd Edition, 1994.
- Minimum Design Loads for Buildings and Other Structures*, ASCE 7-98, Revision of ANSI/ASCE 7-95, January 2000.
- Nolson, A. H., “Shear Diaphragms of Light Gage Steel”, *ASCE Proceedings*, Vol. 86, No. ST11, November 1960.
- PCI Manual for the Design of Hollow Core Slabs*, 2nd Edition, Precast/Prestressed Concrete Institute, 1998.
- Ritchie, J.K. and Chien, E. Y. L., “Composite Structural System-Design”, Canadian Structural Engineering Conference, 1980.
- Robertson Long Span Floor/Ceiling Systems*, H. H. Robertson Company, August 1970.
- Seismic Provisions for Structural Steel Buildings*, American Institute of Steel Construction, 1997.
- Smith, Bryan S. and Coull, Alex, *Tall Building Structures: Analysis and Design*, John Wiley & Sons, 1991.
- “Staggered Truss Framing Systems for High-Rise Buildings”, *USS Technical Report*, May 1971.
- “Staggered Truss Building Systems”, *Civil Engineering*, ASCE, Vol. 39, No. 11, November 1969, page 56.
- Taranath, Bungale S., *Structural Analysis & Design of Tall Buildings*, McGraw-Hill, 1988.
- Taranath, Bungale S., *Steel, Concrete & Composite Design of Tall Buildings*, 1997.
- Wood, Sharon, Stanton, John F., and Hawkins. Neil M., “New Seismic Design Provisions for Diaphragms in Precast Concrete Parking Structures”, *PCI Journal*, V45, N1, January/February 2000, pp. 50-62.
- Whitmore, R. E., *Experimental Investigation of Stesses in Gusset Plates*, Bulletin No. 16, Engineering Experimental Station, University of Tennessee, Knoxville, May 1952.

